

B

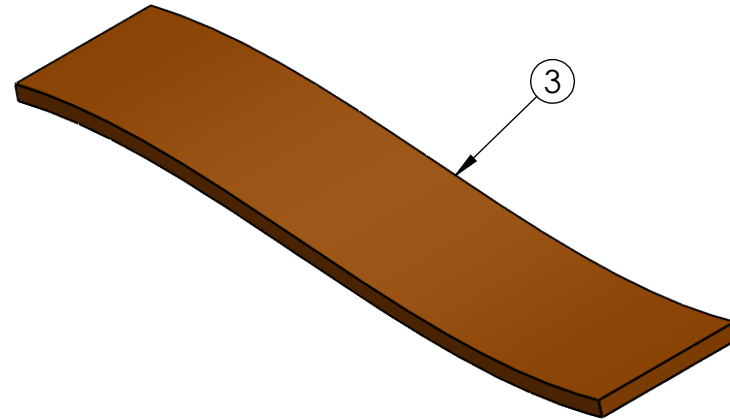

[114.3]
suggested max diameter 4.5
suggested max width 8.5
[215.9]

B

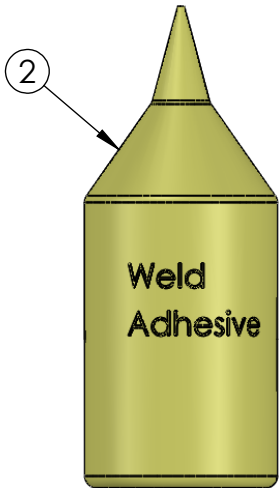
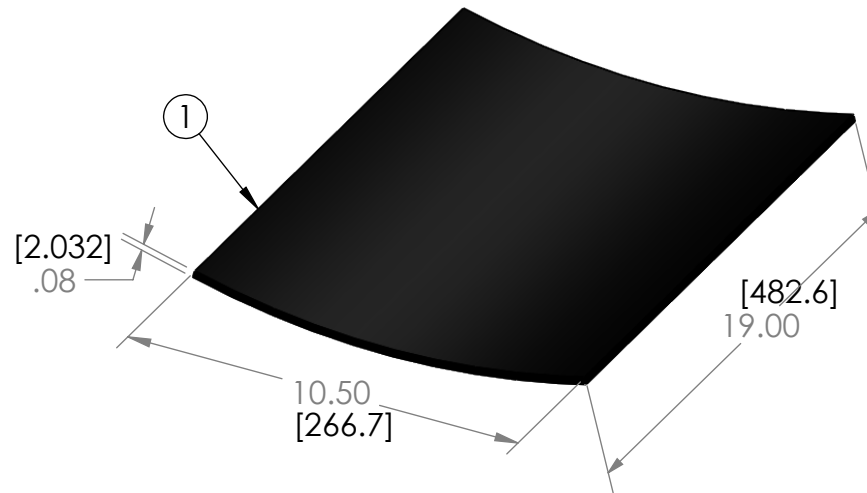

A

ITEM NO.	PART NUMBER	QTY.
1	Heat Shrink Jacket	10
2	Weld Adhesive	1
3	Abrasive Cloth	1
4	Recovered Assembly	10

UNLESS OTHERWISE SPECIFIED:

DIMENSIONS ARE IN INCHES
TOLERANCES:
FRACTIONAL ±
ANGULAR: MACH ± BEND ±
TWO PLACE DECIMAL ±
THREE PLACE DECIMAL ±

INTERPRET GEOMETRIC
TOLERANCING PER:

MATERIAL

FINISH

DO NOT SCALE DRAWING

	NAME	DATE
DRAWN	RB	6-2021
CHECKED		
ENG APPR.		
MFG APPR.		
Q.A.		

COMMENTS:

Jacket supplied
with hot melt glue

TITLE:		
NU-TECH		
NUWS6.00		
SIZE	DWG. NO.	REV
A		
SCALE: 1:1	WEIGHT:	SHEET 1 OF 1

A

2

1