

B

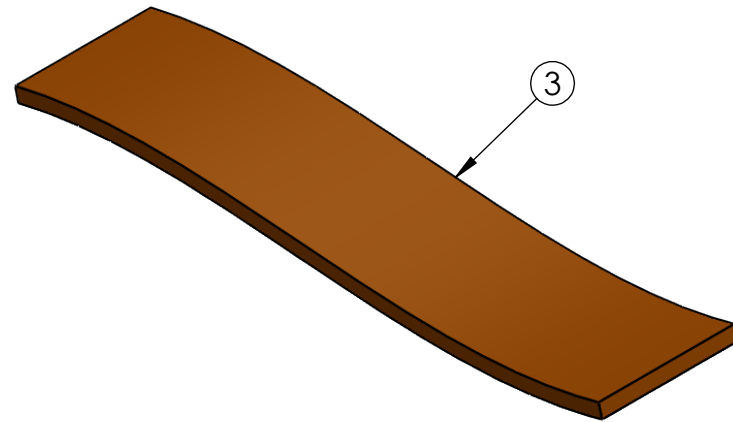

[19.05]
suggested max diameter .75
suggested max width 5.5
[139.7]

B

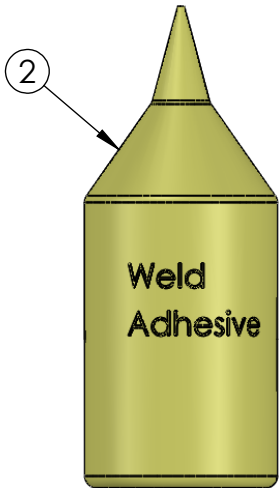
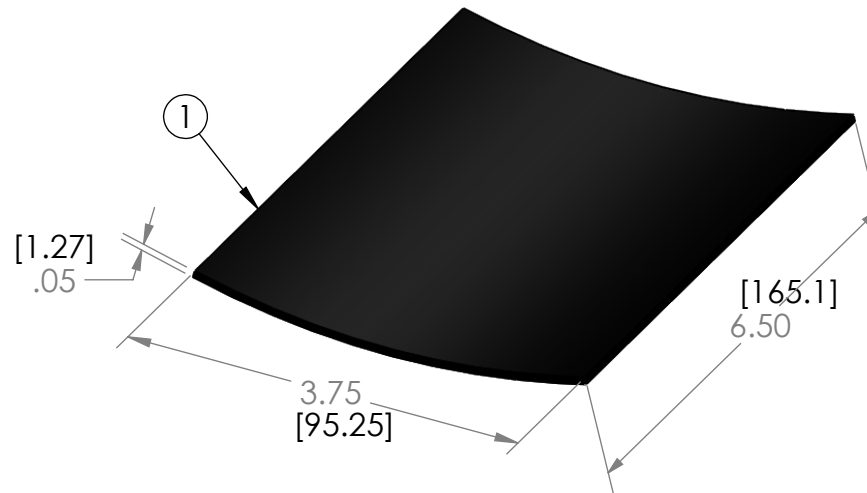

A

ITEM NO.	PART NUMBER	QTY.
1	Heat Shrink Jacket	10
2	Weld Adhesive	1
3	Abrasive Cloth	1
4	Recovered Assembly	10

UNLESS OTHERWISE SPECIFIED:		NAME	DATE	NU-TECH	
DIMENSIONS ARE IN INCHES		DRAWN	RB	6-2021	
TOLERANCES:		CHECKED		TITLE:	
FRACTIONAL ±		ENG APPR.		NUWS200XO75	
ANGULAR: MACH ± BEND ±		MFG APPR.		SIZE	DWG. NO.
TWO PLACE DECIMAL ±		Q.A.		A	REV
THREE PLACE DECIMAL ±		COMMENTS:		SCALE: 1:1	WEIGHT:
INTERPRET GEOMETRIC TOLERANCING PER:		Jacket supplied with hot melt glue		SHEET 1 OF 1	
MATERIAL					
FINISH					
DO NOT SCALE DRAWING					

A

2

1