

B

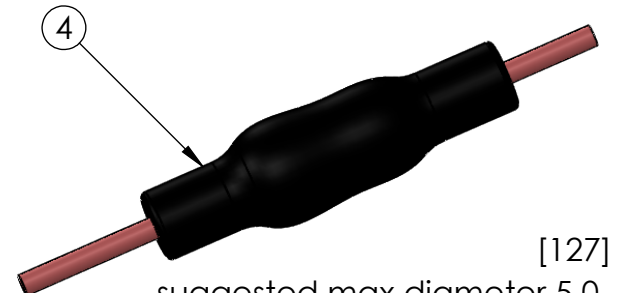

B

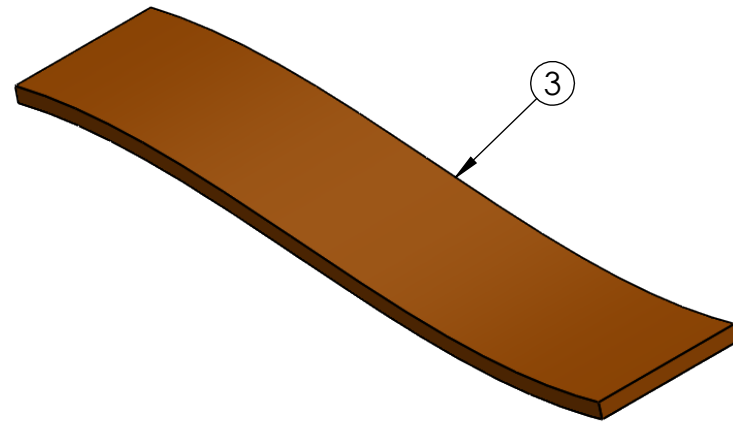
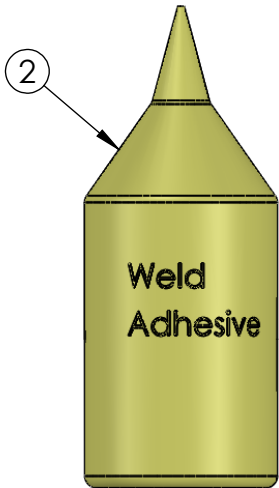
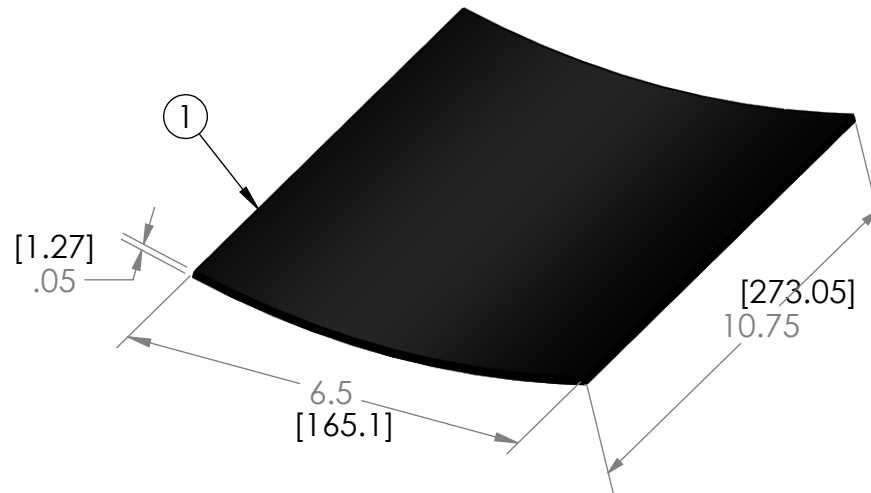

A

ITEM NO.	PART NUMBER	QTY.
1	Heat Shrink Jacket	10
2	Weld Adhesive	1
3	Abrasive Cloth	1
4	Recovered Assembly	10

UNLESS OTHERWISE SPECIFIED:

DIMENSIONS ARE IN INCHES
 TOLERANCES:
 FRACTIONAL \pm
 ANGULAR: MACH \pm BEND \pm
 TWO PLACE DECIMAL \pm
 THREE PLACE DECIMAL \pm

INTERPRET GEOMETRIC
 TOLERANCING PER:

MATERIAL

FINISH

DO NOT SCALE DRAWING

	NAME	DATE
DRAWN	RB	6-2021
CHECKED		
ENG APPR.		
MFG APPR.		
Q.A.		

COMMENTS:

Jacket supplied
 with hot melt glue

TITLE:		
NU-TECH		
NUWS2.00		
SIZE	DWG. NO.	REV
A		
SCALE: 1:1	WEIGHT:	SHEET 1 OF 1

2

1