

REVISIONS		
REV.	DESCRIPTION	DATE
A	UPDATE DRAWING TO 2025 STANDARDS	9/23/2025
B	REFINE DIMENSIONS AND DECIMAL PRECISION	12/16/2025
C	UPDATE TOLERANCE TABLE	12/29/2025

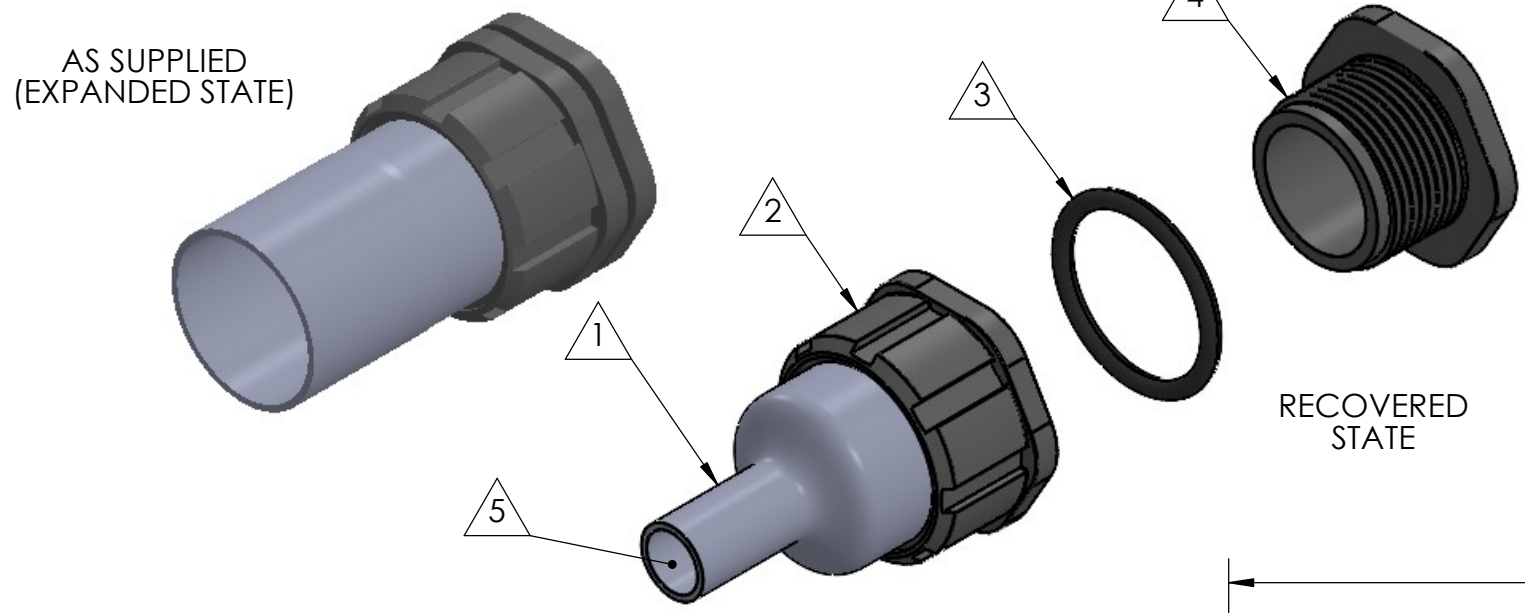

NOTE: REFERENCE FOR SEAL ASSEMBLY INSTALLATION:
 ASSEMBLY MAY BE INSTALLED IN PANELS FROM
 0.11"(2.97mm) - 0.63"(15.9mm).
 RECCOMENDED DRILL HOLE DIAMETER
 OF 2.00" (50.8mm)

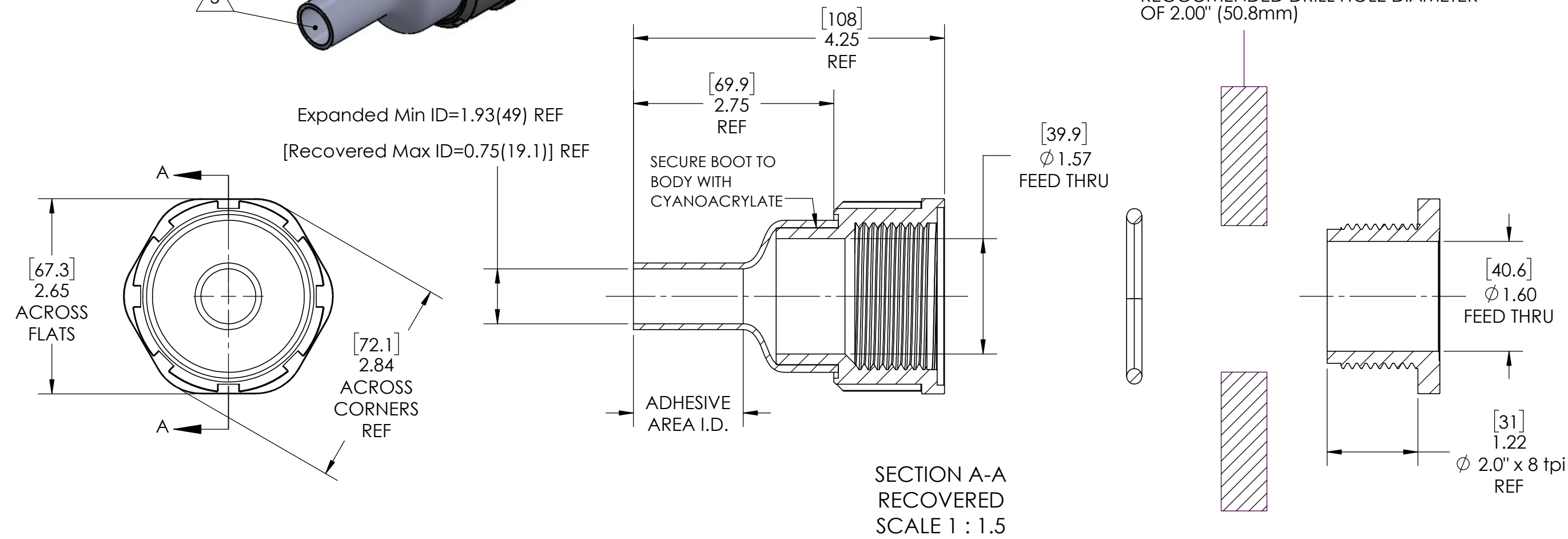

- NOTES:
- ITEM#1 HEAT SHRINKABLE BOOT MATERIAL IS IN ACCORDANCE WITH POLYOLEFIN STANDARDS DEFINED IN SAE AS81765/1 REFERENCE DIMENSIONS MAY DEVIATE AS MUCH AS +OR- 1/4"
 - FACTORY APPLIED HOT MELT ADHESIVE IS STANDARD

ITEM	PART DESCRIPTION	PART NO.	MATERIAL
①	Heat-shrinkable boot	S-4 BOOT	Flame Retardant Polyolefin
②	Body	S-4B	Glass Fiber Reinforced, PBT
③	O-ring	AS-329	Buna
④	Nut	S-4N	Glass Fiber Reinforced, PBT
⑤	Adhesive		Hotmelt Polyamide

NU-TECH

UNLESS OTHERWISE SPECIFIED: DIMENSIONS ARE IN INCHES TOLERANCES: FRACTIONAL ± 1/32 ONE DECIMAL PLACE ± 0.060 TWO DECIMAL PLACE ± 0.025 THREE DECIMAL PLACE ± 0.010	PART NO. NUS-4	
	DWG. NO. NUS-4-ASSY	
	WEIGHT: 0.384	REV C
	DRAWN: MLJ	DATE: 2/3/2026
SCALE: 1:1.5	SHEET 1 OF 1	

PROPRIETARY AND CONFIDENTIAL
 THE INFORMATION CONTAINED IN THIS DRAWING IS THE SOLE PROPERTY OF Cross Technology INC. ANY REPRODUCTION IN PART OR AS A WHOLE WITHOUT THE WRITTEN PERMISSION OF Cross Technology INC. IS PROHIBITED.