

8 7 6 5 4 3 2 1

D

D

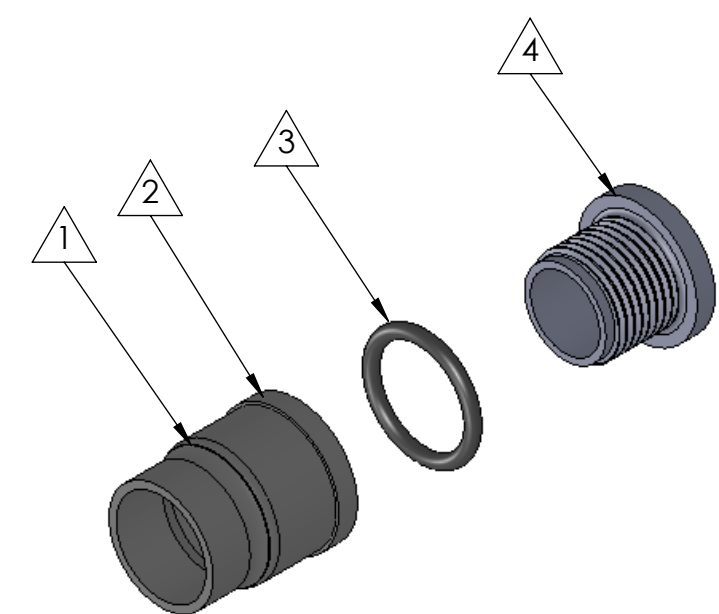
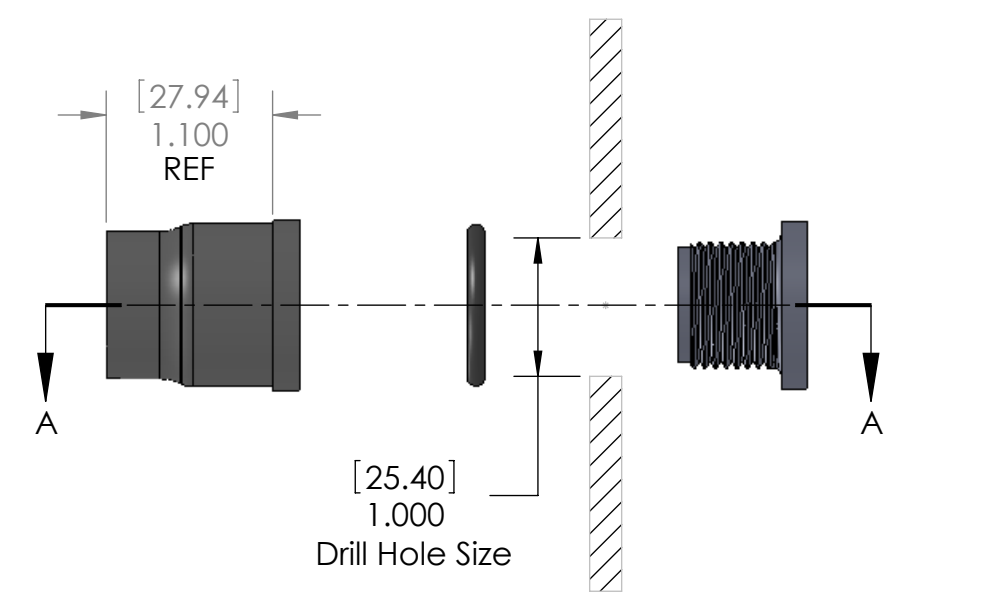

C

C

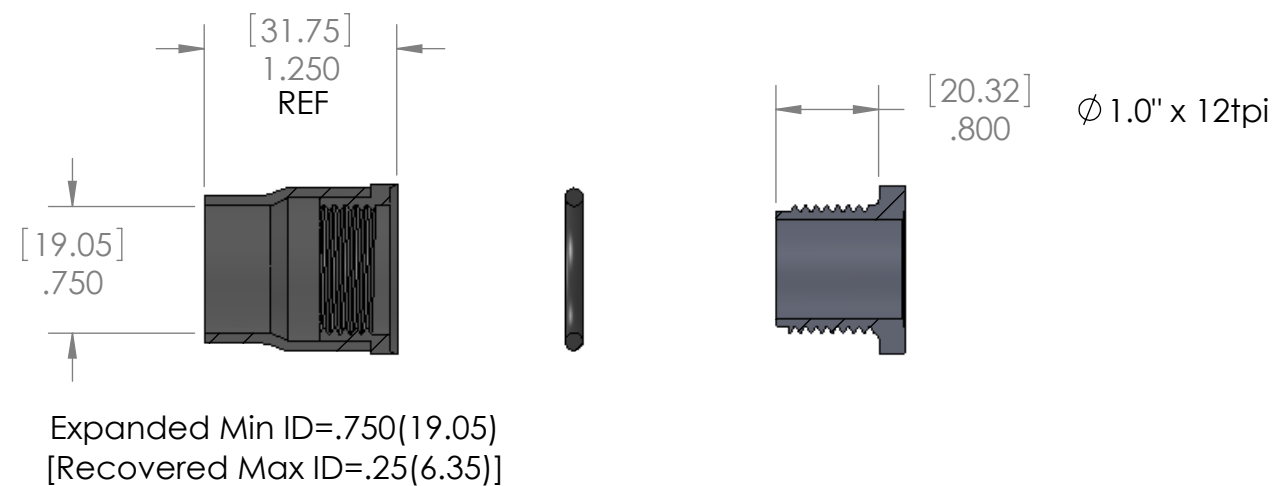

B

B

A

A

SECTION A-A

ITEM	PART DESCRIPTION	PART NO.	MATERIAL	Nu-Tech	
1	Heat-shrinkable boot	M-1/8" x 1.5" Tube	HS 3123		
2	Body	S-2XB	Nylon	DWG. NO. S-020-X-AEA	
3	O-ring	S-2OR	Buna		
4	Nut	S-2XN	Nylon	SCALE: 2:3 SHEET 1 OF 1	
5	Adhesive	A-010	Hotmelt ADH		
6					

UNLESS OTHERWISE SPECIFIED:
 DIMENSIONS ARE IN INCHES
 TOLERANCES:
 FRACTIONAL $\pm 1/32$
 THREE PLACE DECIMAL ± 0.030
 DO NOT SCALE DRAWING

8 7 6 5 4 3 2 1