

8 7 6 5 4 3 2 1

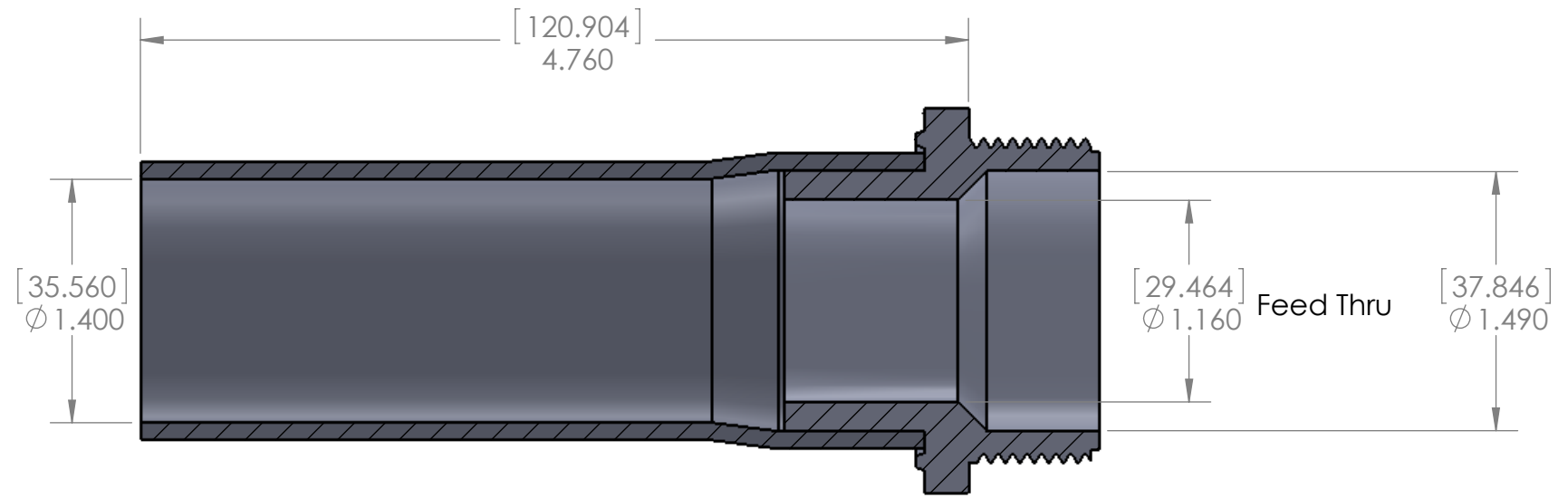
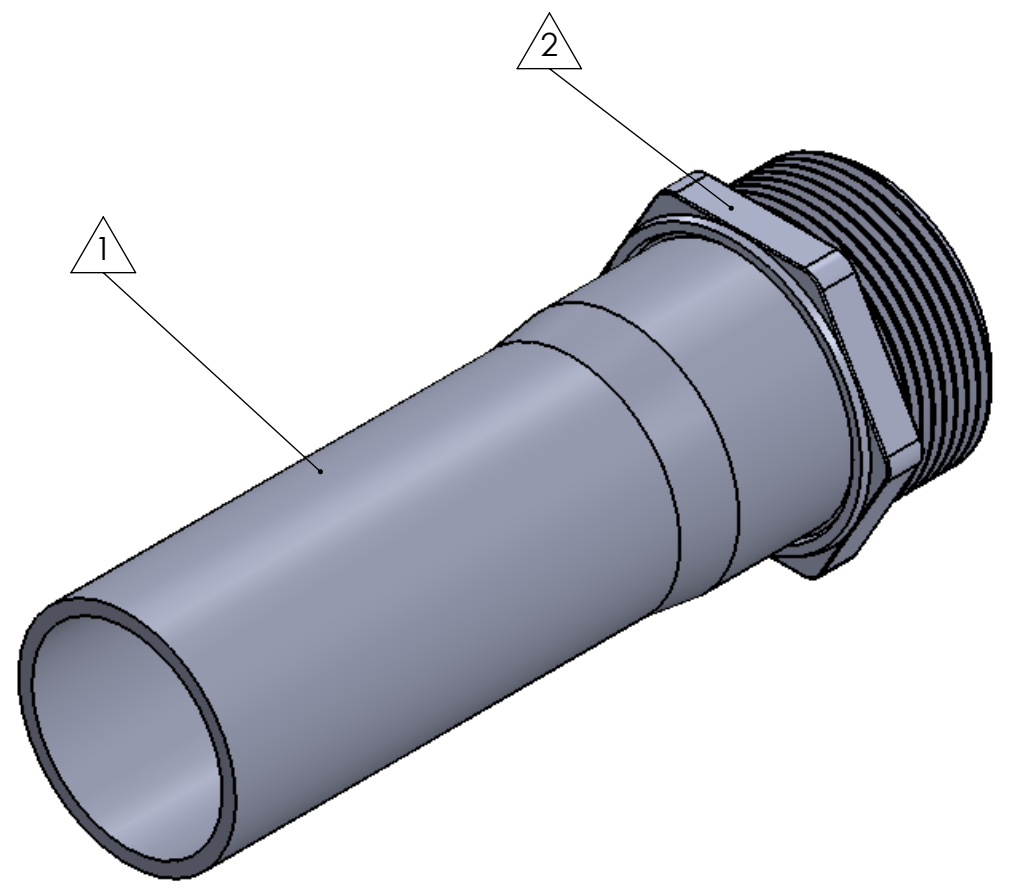
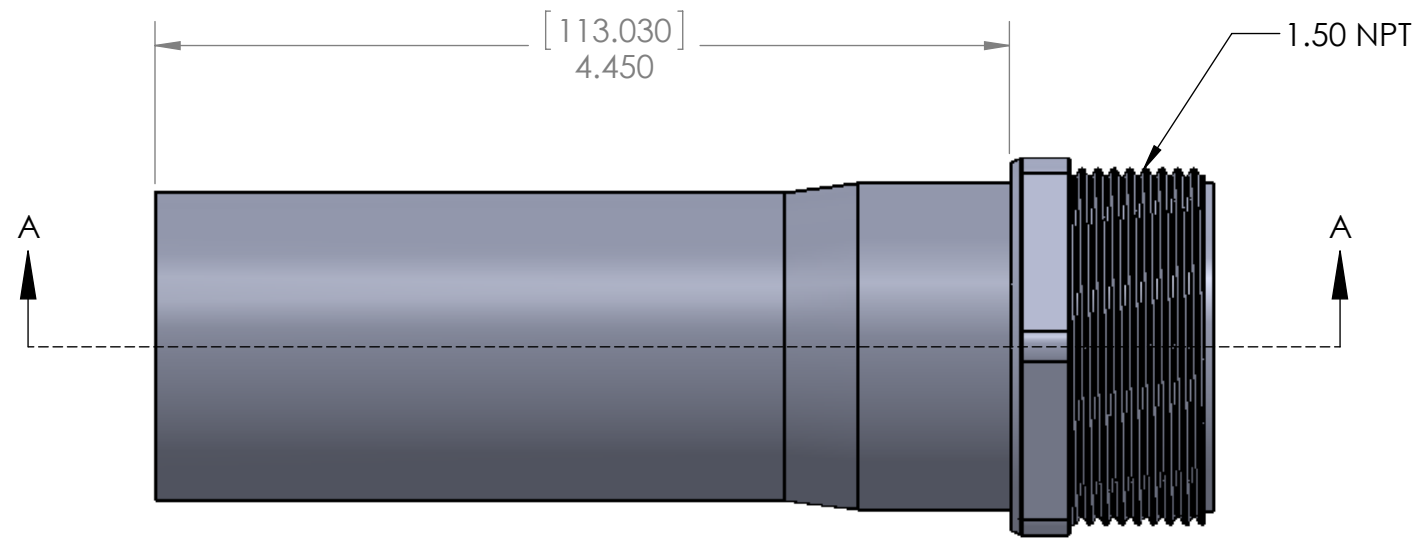

SECTION A-A  
SCALE 1 : 1

Expanded Min ID=1.40(35.56)  
[Recovered Max ID=0.500(12.7)]

ITEM	PART DESCRIPTION	PART NO.	MATERIAL
①	Heat-shrinkable boot	M-1/2" x 5" HRT	HS 3123
②	Body	P-4	Nylon
③	O-ring		Buna
④	Nut		Nylon
⑤	Adhesive	A-010	Hotmelt ADH
⑥			

**Nu-Tech**

UNLESS OTHERWISE SPECIFIED:  
DIMENSIONS ARE IN INCHES  
TOLERANCES:  
FRACTIONAL ±1/32  
THREE PLACE DECIMAL ± 0.030

PART NO.	NUP-4	
DWG. NO.	PRP:"SW-Title"	
WEIGHT:	SW-Mass@par19.SLDPRT	REV
DRAWN: HH	DATE: 7/31/2014	SCALE: 1:2
		SHEET 1 OF 1

8 7 6 5 4 3 2 1