

REVISIONS		
REV.	DESCRIPTION	DATE
A	UPDATE DRAWING TO 2025 STANDARDS	2/18/2026

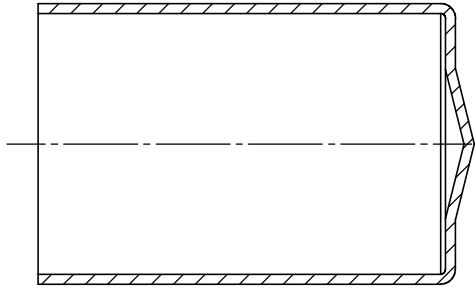

SECTION B-B
EXPANDED
SCALE 1:1

AS SUPPLIED
(EXPANDED STATE)

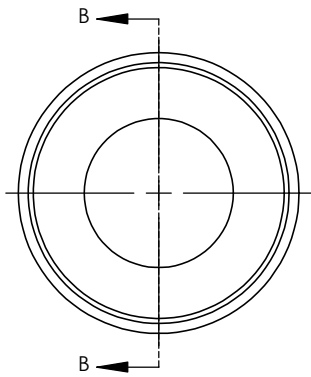
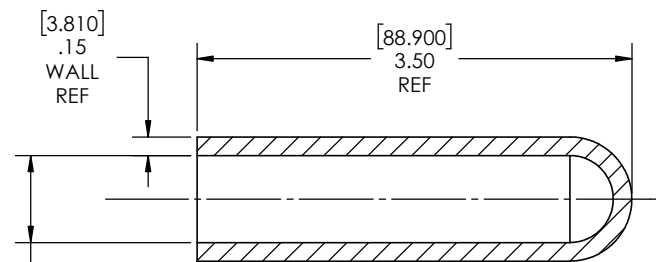
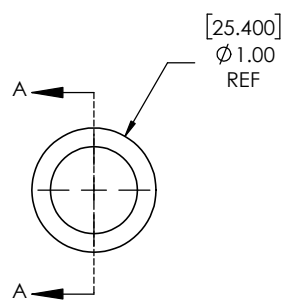
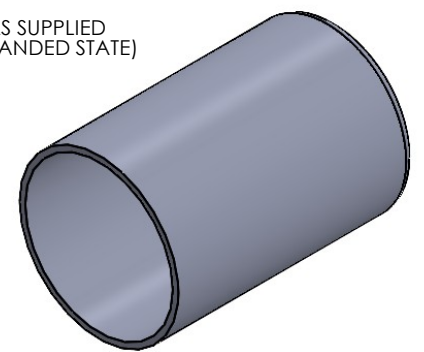

SECTION A-A
RECOVERED
SCALE 1:1

Expanded Min ID= 2.10(53.3) REF
[Recovered Max ID = 0.70(17.8)] REF

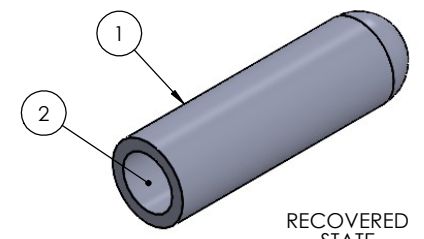

RECOVERED
STATE

NOTES:

- ITEM# 1 - HEAT SHRINKABLE BOOT MATERIAL IS IN ACCORDANCE WITH POLYOLEFIN STANDARDS DEFINED IN SAE AS81765/1 REFERENCE DIMENSIONS MAY DEVIATE AS MUCH AS +OR- 1/4"
- ITEM# 2 - FACTORY APPLIED HOT MELT ADHESIVE IS STANDARD - INTERIOR SURFACES.

ITEM	PART DESCRIPTION	PART NO.	MATERIAL
1	HEAT SHRINKABLE BOOT	M-NU200X075	FLAME RETARDANT POLYOLEFIN
2	ADHESIVE		HOTMELT POLYAMIDE

PROPRIETARY AND CONFIDENTIAL
THE INFORMATION CONTAINED IN THIS DRAWING IS THE SOLE PROPERTY OF Cross Technology INC. ANY REPRODUCTION IN PART OR AS A WHOLE WITHOUT THE WRITTEN PERMISSION OF Cross Technology INC. IS PROHIBITED.

NU-TECH

UNLESS OTHERWISE SPECIFIED: DIMENSIONS ARE IN INCHES TOLERANCES: FRACTIONAL ±1/16 ONE DECIMAL PLACE ± 0.200 TWO DECIMAL PLACE ± 0.100 THREE DECIMAL PLACE ± 0.050	PART DESC. NU200X075
DWG. NO. NU200X075	REV A
WEIGHT: 0.070	SCALE: 1:1
DRAWN: MLJ DATE: 2/19/2026	SHEET 1 OF 1

DO NOT SCALE DRAWING