

8 7 6 5 4 3 2 1

REVISIONS		
REV.	DESCRIPTION	DATE
A	UPDATE DRAWING TO 2025 STANDARDS. UPDATE TOLERANCE TABLE AND DECIMAL PRECISION	1/7/2026

AS SUPPLIED
(EXPANDED STATE)

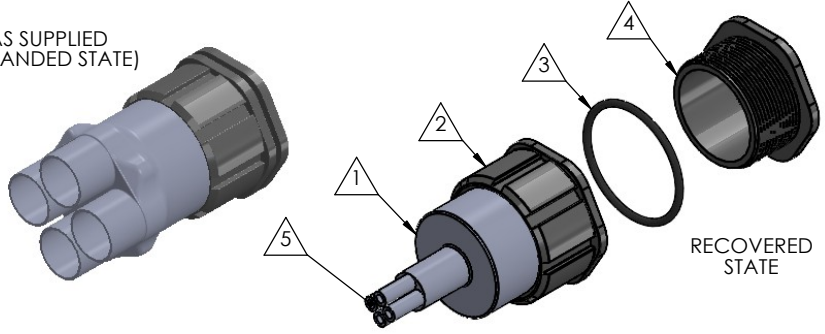

RECOVERED
STATE

NOTE: REFERENCE FOR SEAL ASSEMBLY INSTALLATION:
ASSEMBLY MAY BE INSTALLED IN PANELS FROM
0.18" (4.4mm) - 0.88" (22.4mm).
RECCOMENDED DRILL HOLE DIAMETER
OF 3.50" (88.9mm)

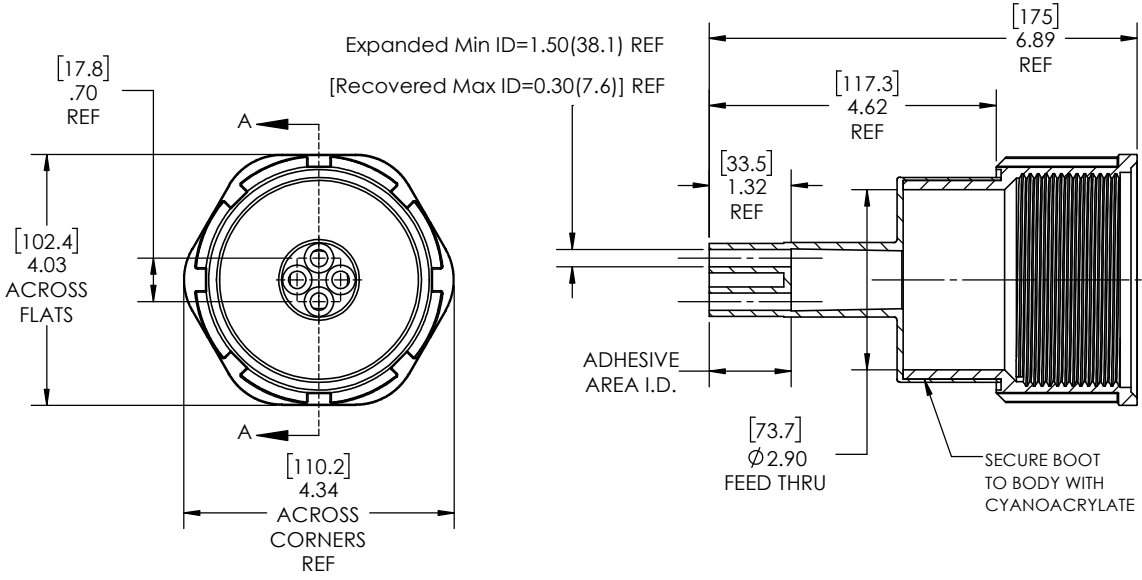

SECTION A-A
RECOVERED
SCALE 1 : 2

NOTES:

- ITEM#1 HEAT SHRINKABLE BOOT MATERIAL IS IN ACCORDANCE WITH POLYOLEFIN STANDARDS DEFINED IN SAE AS81765/1 REFERENCE DIMENSIONS MAY DEVIATE AS MUCH AS +OR- 1/4"
- FACTORY APPLIED HOT MELT ADHESIVE IS STANDARD

ITEM	PART DESCRIPTION	PART NO.	MATERIAL
1	Heat-shrinkable boot	NUBB4-5	Flame Retardant Polyolefin
2	Body	S-5B	Glass Fiber Reinforced, PBT
3	O-ring	AS-340	Buna
4	Nut	S-5N	Glass Fiber Reinforced, PBT
5	Adhesive		Hotmelt Polyamide

NU-TECH

UNLESS OTHERWISE SPECIFIED: DIMENSIONS ARE IN INCHES TOLERANCES: FRACTIONAL ±1/32 ONE DECIMAL PLACE ± 0.060 TWO DECIMAL PLACE ± 0.025 THREE DECIMAL PLACE ± 0.010 DO NOT SCALE DRAWING	PART NO.	5-NUS-4E	
	DWG. NO.	5-NUS-4E-ASSY	
	WEIGHT:	0.849	REV A
	DRAWN: MLJ	DATE: 2/3/2026	SCALE: 1:2

PROPRIETARY AND CONFIDENTIAL
THE INFORMATION CONTAINED IN THIS DRAWING IS THE SOLE PROPERTY OF Cross Technology INC. ANY REPRODUCTION IN PART OR AS A WHOLE WITHOUT THE WRITTEN PERMISSION OF Cross Technology INC. IS PROHIBITED.

8 7 6 5 4 3 2 1