

8 7 6 5 4 3 2 1

REVISIONS		
REV.	DESCRIPTION	DATE
A	UPDATE DRAWING TO 2025 STANDARDS. UPDATE TOLERANCE TABLE AND DECIMAL PRECISION	1/6/2026

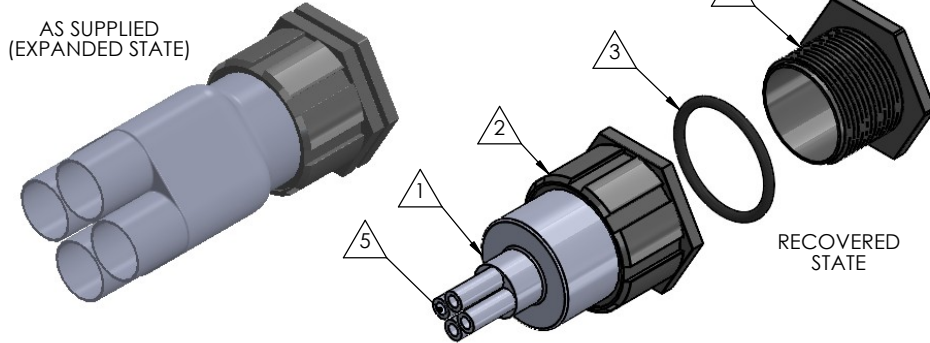

NOTE: REFERENCE FOR SEAL ASSEMBLY INSTALLATION:
 ASSEMBLY MAY BE INSTALLED IN PANELS FROM
 0.18"(4.4mm) - 0.95"(24.1mm).
 RECCOMENDED DRILL HOLE DIAMETER
 OF 2.36" (60.0mm)

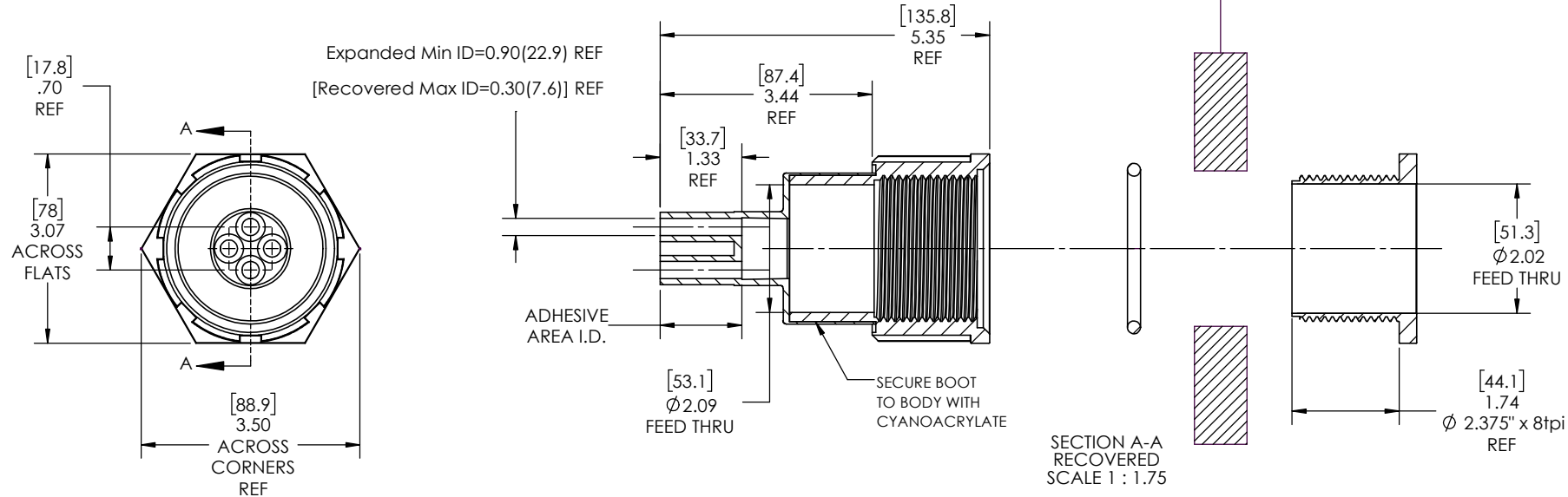

- NOTES:
- ITEM#1 HEAT SHRINKABLE BOOT MATERIAL IS IN ACCORDANCE WITH POLYOLEFIN STANDARDS DEFINED IN SAE AS81765/1 REFERENCE DIMENSIONS MAY DEVIATE AS MUCH AS +OR- 1/4"
 - FACTORY APPLIED HOT MELT ADHESIVE IS STANDARD

ITEM	PART DESCRIPTION	PART NO.	MATERIAL
1	Heat-shrinkable boot	NUBB4-3	Flame Retardant Polyolefin
2	Body	S-4XB	Glass Fiber Reinforced, PBT
3	O-ring	AS-332	Buna
4	Nut	S-4XN	Glass Fiber Reinforced, PBT
5	Adhesive		Hotmelt Polyamide

NU-TECH

UNLESS OTHERWISE SPECIFIED: DIMENSIONS ARE IN INCHES TOLERANCES: FRACTIONAL ±1/32 ONE DECIMAL PLACE ± 0.060 TWO DECIMAL PLACE ± 0.025 THREE DECIMAL PLACE ± 0.010 DO NOT SCALE DRAWING	PART NO.	
	4X-NUS-4C	
	DWG. NO. 4X-NUS-4C-ASSY	
	WEIGHT: 0.505	REV A
DRAWN: MLJ	DATE: 2/3/2026	SCALE: 1:1.75
		SHEET 1 OF 1

8 7 6 5 4 3 2 1