

8 7 6 5 4 3 2 1

REVISIONS		
REV.	DESCRIPTION	DATE
A	UPDATE DRAWING TO 2025 STANDARDS. UPDATE TOLERANCE TABLE AND DECIMAL PRECISION	1/5/2026

AS SUPPLIED  
(EXPANDED STATE)

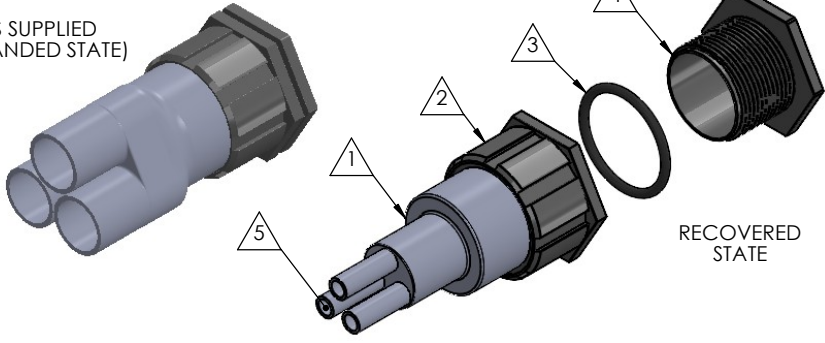

RECOVERED STATE

NOTE: REFERENCE FOR SEAL ASSEMBLY INSTALLATION:  
ASSEMBLY MAY BE INSTALLED IN PANELS FROM  
0.18"(4.4mm) - 0.95"(24.1mm).  
RECOMMENDED DRILL HOLE DIAMETER  
OF 2.36" (60.0mm)

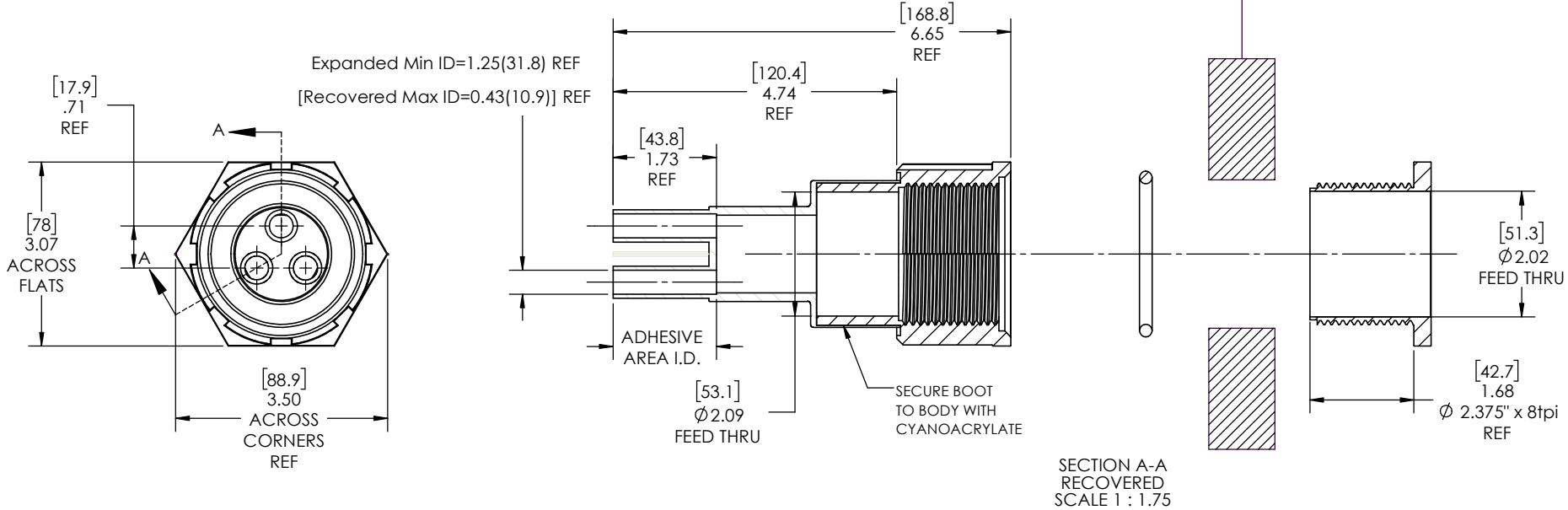

- NOTES:
- ITEM#1 HEAT SHRINKABLE BOOT MATERIAL IS IN ACCORDANCE WITH POLYOLEFIN STANDARDS DEFINED IN SAE AS81765/1 REFERENCE DIMENSIONS MAY DEVIATE AS MUCH AS +OR- 1/4"
  - FACTORY APPLIED HOT MELT ADHESIVE IS STANDARD

ITEM	PART DESCRIPTION	PART NO.	MATERIAL
1	Heat-shrinkable boot	NUBB3-4	Flame Retardant Polyolefin
2	Body	S-4XB	Glass Fiber Reinforced, PBT
3	O-ring	AS-332	Buna
4	Nut	S-4XN	Glass Fiber Reinforced, PBT
5	Adhesive		Hotmelt Polyamide

**NU-TECH**

UNLESS OTHERWISE SPECIFIED: DIMENSIONS ARE IN INCHES TOLERANCES: FRACTIONAL ±1/32 ONE DECIMAL PLACE ± 0.060 TWO DECIMAL PLACE ± 0.025 THREE DECIMAL PLACE ± 0.010 DO NOT SCALE DRAWING	PART NO. <b>4X-NUS-3D</b>	
	DWG. NO. 4X-NUS-3D-ASSY	
	WEIGHT: 0.525	REV A
	SCALE: 1:1.75	SHEET 1 OF 1

**PROPRIETARY AND CONFIDENTIAL**  
THE INFORMATION CONTAINED IN THIS DRAWING IS THE SOLE PROPERTY OF Cross Technology INC. ANY REPRODUCTION IN PART OR AS A WHOLE WITHOUT THE WRITTEN PERMISSION OF Cross Technology INC. IS PROHIBITED.

8 7 6 5 4 3 2 1