

8 7 6 5 4 3 2 1

REVISIONS		
REV.	DESCRIPTION	DATE
A	UPDATE DRAWING TO 2025 STANDARDS	1/22/2026

AS SUPPLIED  
(EXPANDED STATE)

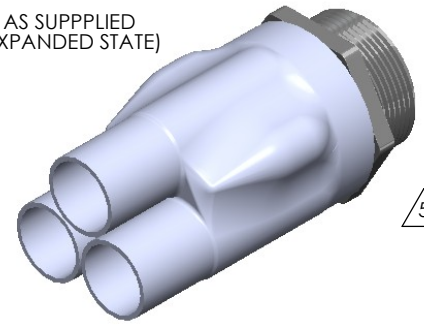

RECOVERED  
STATE

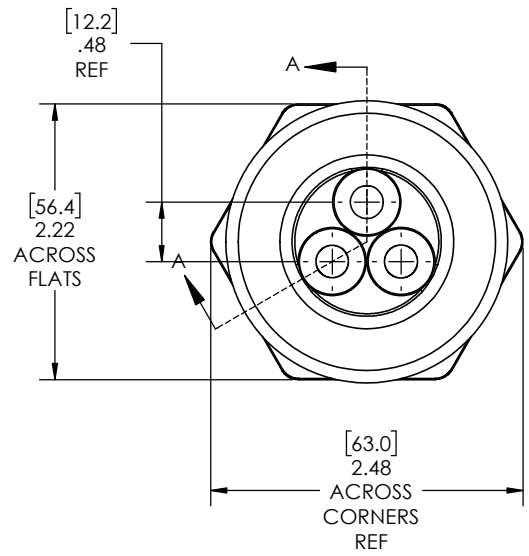
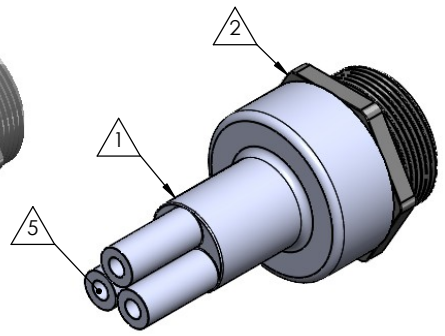

Expanded Min ID=0.95(24.1) REF  
[Recovered Max ID=0.28(7.1)] REF

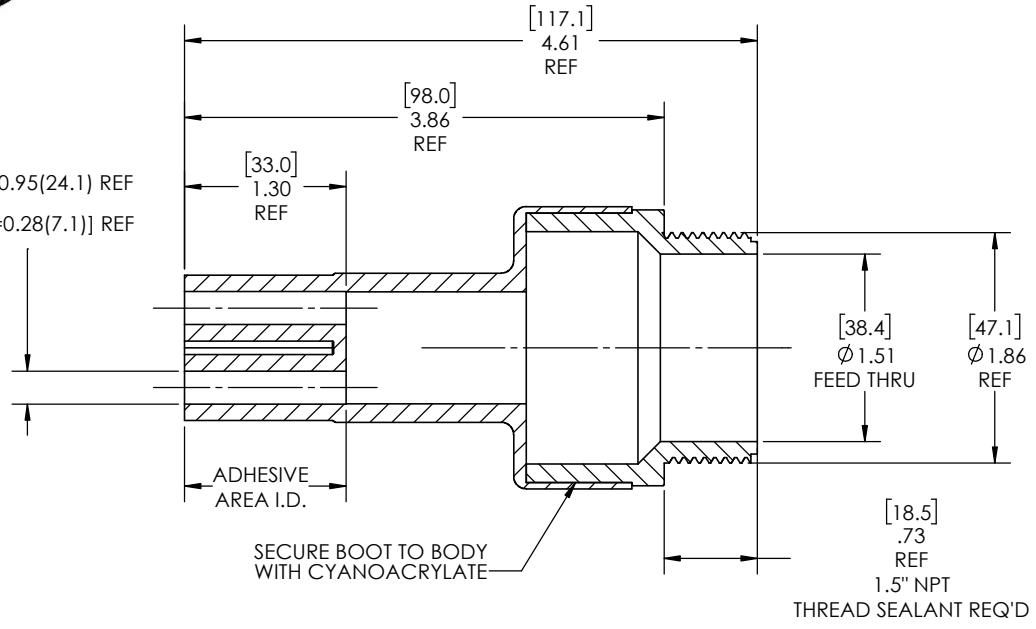

SECTION A-A  
RECOVERED  
SCALE 1:1

NOTES:

- ITEM #1 HEAT SHRINKABLE BOOT MATERIAL IS IN ACCORDANCE WITH POLYOLEFIN STANDARDS DEFINED IN SAE AS81765/1 REFERENCE DIMENSIONS MAY DEVIATE AS MUCH AS +OR- 1/4"
- FACTORY APPLIED HOT MELT ADHESIVE IS STANDARD

ITEM	PART DESCRIPTION	PART NO.	MATERIAL
1	Heat-shrinkable boot	NUBB3-3	Flame Retardant Polyolefin
2	Body	P-4AB	Glass Fiber Reinforced, PBT
5	Adhesive		Hotmelt Polyamide

**NU-TECH**

UNLESS OTHERWISE SPECIFIED: DIMENSIONS ARE IN INCHES TOLERANCES: FRACTIONAL ± 1/32 ONE DECIMAL PLACE ± 0.060 TWO DECIMAL PLACE ± 0.025 THREE DECIMAL PLACE ± 0.010 DO NOT SCALE DRAWING	PART NO. <b>4A-NUP-3C</b>	
	DWG. NO. 4A-NUP-3C-ASSY	
	WEIGHT: 0.193	REV A
	SCALE: 1:1	SHEET 1 OF 1

**PROPRIETARY AND CONFIDENTIAL**  
THE INFORMATION CONTAINED IN THIS DRAWING IS THE SOLE PROPERTY OF Cross Technology INC. ANY REPRODUCTION IN PART OR AS A WHOLE WITHOUT THE WRITTEN PERMISSION OF Cross Technology INC. IS PROHIBITED.

8 7 6 5 4 3 2 1