

8 7 6 5 4 3 2 1

REVISIONS		
REV.	DESCRIPTION	DATE
A	UPDATE DRAWING TO 2025 STANDARDS	10/21/2025
B	UPDATE TOLERANCE TABLE	1/13/2026
C	ADJUST EXPANDED REFERENCE LENGTH TO REFLECT ACTUAL EXPANDED STATE PART SAMPLES	3/5/2026

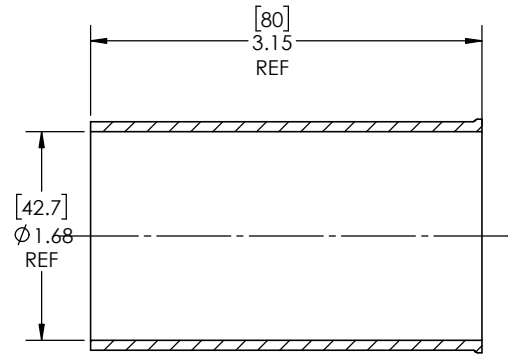
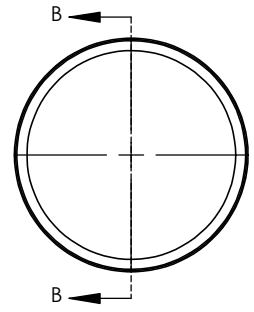

SECTION B-B
EXPANDED
SCALE 1:1

AS SUPPLIED
(EXPANDED STATE)

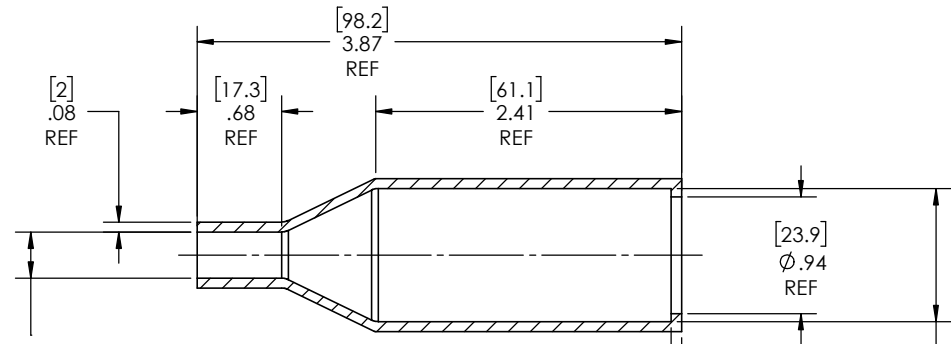
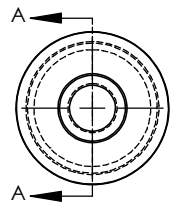
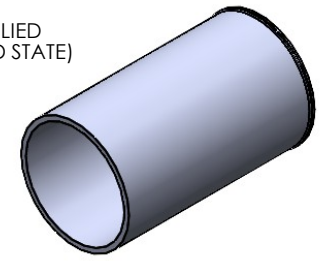

SECTION A-A
RECOVERED
SCALE 1:1

Expanded Min ID= 1.68(42.7) REF
[Recovered Max ID= 0.37(9.4)] REF

Expanded Min ID= 1.68(42.7) REF
[Recovered Max ID= 1.07(27.2)] REF

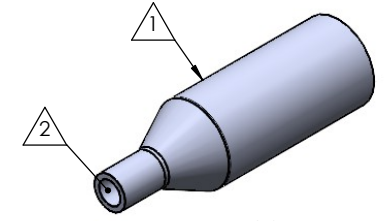

RECOVERED
STATE

NOTES:

- ITEM#1 - HEAT SHRINKABLE BOOT MATERIAL IS IN ACCORDANCE WITH POLYOLEFIN STANDARDS DEFINED IN SAE AS81765/1 REFERENCE DIMENSIONS MAY DEVIATE AS MUCH AS +OR- 1/4"
- ITEM#2 - FACTORY APPLIED HOT MELT ADHESIVE IS STANDARD - INTERIOR SURFACES.

ITEM	PART DESCRIPTION	PART NO.	MATERIAL
①	HEAT SHRINKABLE BOOT	M-432L15	FLAME RETARDANT POLYOLEFIN
②	ADHESIVE		HOTMELT POLYAMIDE

PROPRIETARY AND CONFIDENTIAL
THE INFORMATION CONTAINED IN THIS DRAWING IS THE SOLE PROPERTY OF Cross Technology INC. ANY REPRODUCTION IN PART OR AS A WHOLE WITHOUT THE WRITTEN PERMISSION OF Cross Technology INC. IS PROHIBITED.

NU-TECH

UNLESS OTHERWISE SPECIFIED: DIMENSIONS ARE IN INCHES TOLERANCES: FRACTIONAL ± 1/16 ONE DECIMAL PLACE ± 0.200 TWO DECIMAL PLACE ± 0.100 THREE DECIMAL PLACE ± 0.050	PART DESC. 432L15
DWG. NO. 432L15	REV C
WEIGHT: 0.034	SCALE: 1:1
DRAWN: MLJ DATE: 3/24/2026	SHEET 1 OF 1

8 7 6 5 4 3 2 1