

8 7 6 5 4 3 2 1

AS SUPPLIED
(EXPANDED STATE)

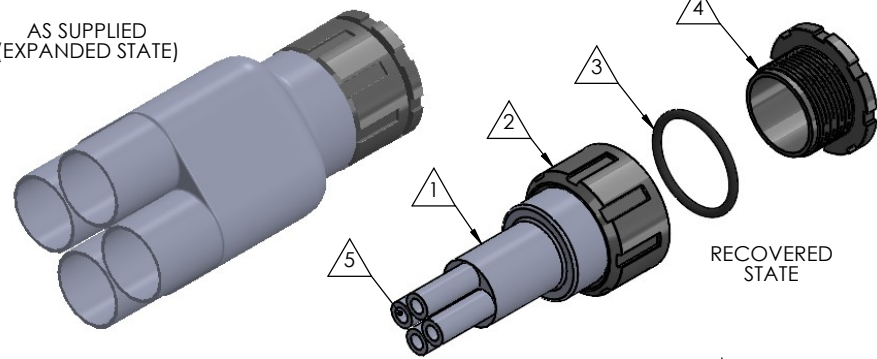

REVISIONS		
REV.	DESCRIPTION	DATE
A	UPDTAE DRAWING TO 2025 STANDARDS	12/18/2025
B	UPDATE TOLERANCE TABLE AND DECIMAL PRECISION	12/30/2025

NOTE: REFERENCE FOR SEAL ASSEMBLY INSTALLATION:
ASSEMBLY MAY BE INSTALLED IN PANELS FROM
0.12"(3.1mm) - 0.48"(12.2mm).
RECCOMENDED DRILL HOLE DIAMETER
OF 1.65" (41.9mm)

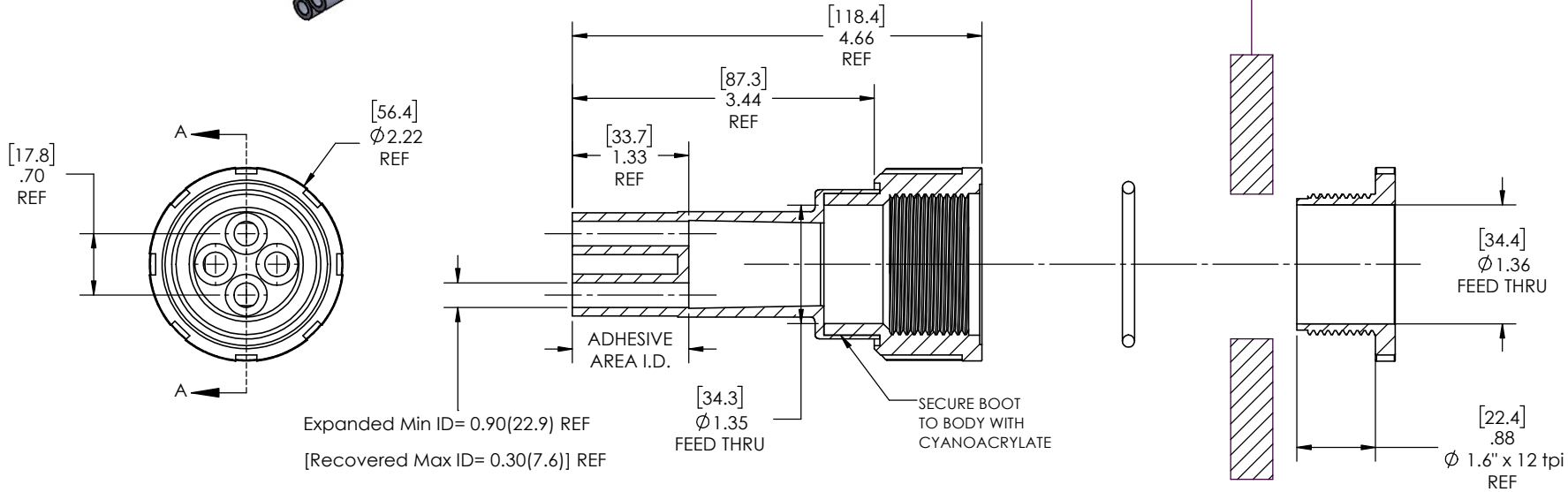

SECTION A-A
RECOVERED
SCALE 1 : 1.25

- NOTES:
- ITEM#1 HEAT SHRINKABLE BOOT MATERIAL IS IN ACCORDANCE WITH POLYOLEFIN STANDARDS DEFINED IN SAE AS81765/1 REFERENCE DIMENSIONS MAY DEVIATE AS MUCH AS +OR- 1/4"
 - FACTORY APPLIED HOT MELT ADHESIVE IS STANDARD

ITEM	PART DESCRIPTION	PART NO.	MATERIAL
1	Heat-shrinkable boot	NUBB4-3	Flame Retardant Polyolefin
2	Body	S-3XB	Glass Fiber Reinforced, PBT
3	O-ring	AS-223	Buna
4	Nut	S-3XN	Glass Fiber Reinforced, PBT
5	Adhesive		Hotmelt Polyamide

NU-TECH

UNLESS OTHERWISE SPECIFIED: DIMENSIONS ARE IN INCHES TOLERANCES: FRACTIONAL: 1/32 ONE DECIMAL PLACE ± 0.060 TWO DECIMAL PLACE ± 0.025 THREE DECIMAL PLACE ± 0.010 DO NOT SCALE DRAWING	PART NO.	
	3X-NUS-4C	
	DWG. NO. 3X-NUS-4C-ASSY	
	WEIGHT: 0.263	REV B
DRAWN: MLJ	DATE: 2/3/2026	SCALE: 1:1.25
		SHEET 1 OF 1

8 7 6 5 4 3 2 1

8 7 6 5 4 3 2 1