

8 7 6 5 4 3 2 1

AS SUPPLIED
(EXPANDED STATE)

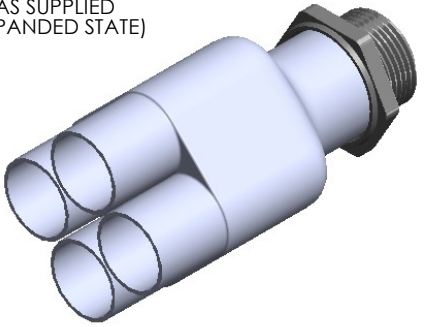

RECOVERED
STATE

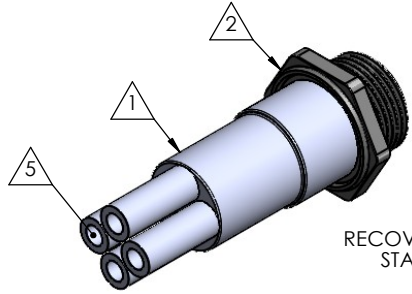

REVISIONS		
REV.	DESCRIPTION	DATE
A	UPDSTE DRAWING TO 2025 STANDARDS	1/15/2026

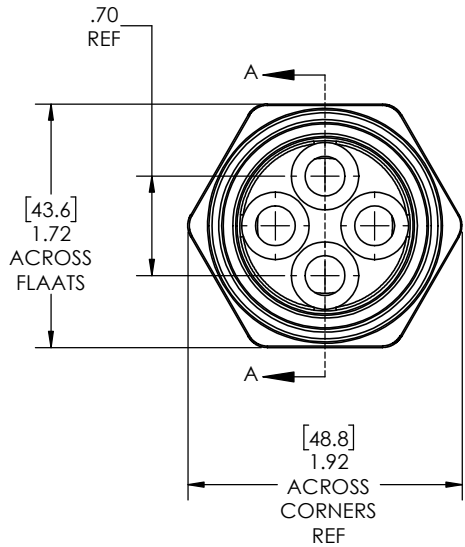

Expanded Min ID=0.95(24.1) REF
[Recovered Max ID=0.28(7.1)] REF

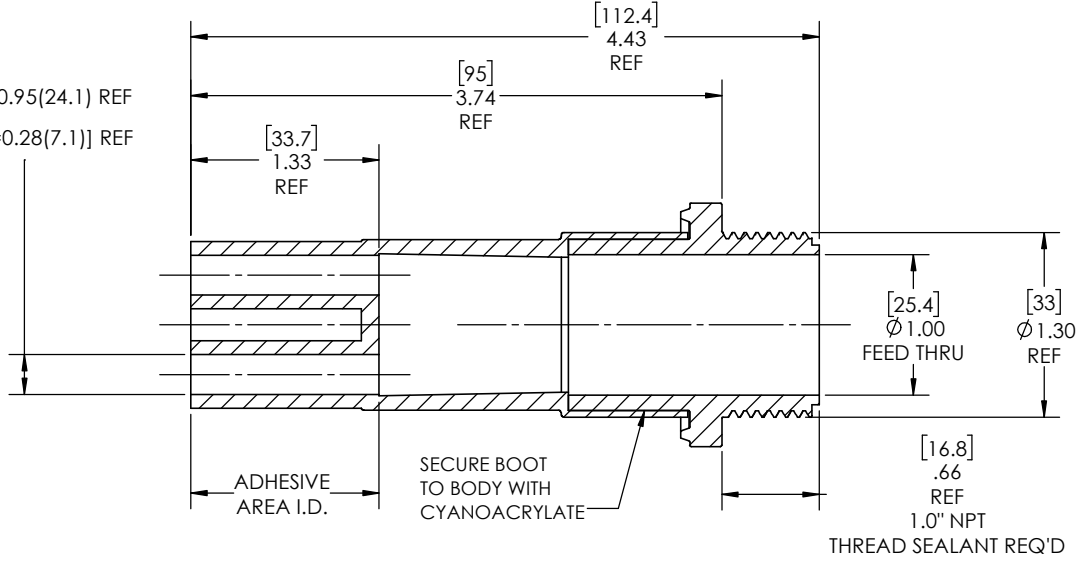

SECTION A-A
RECOVERED
SCALE 2 : 1.75

NOTES:

- ITEM#1 HEAT SHRINKABLE BOOT MATERIAL IS IN ACCORDANCE WITH POLYOLEFIN STANDARDS DEFINED IN SAE AS81765/1 REFERENCE DIMENSIONS MAY DEVIATE AS MUCH AS +OR- 1/4"
- FACTORY APPLIED HOT MELT ADHESIVE IS STANDARD

ITEM	PART DESCRIPTION	PART NO.	MATERIAL
1	Heat-shrinkable boot	NUBB4-3	Flame Retardant Polyolefin
2	Body	P-3AB	Glass Fiber Reinforced, PBT
5	Adhesive		Hotmelt Polyamide

NU-TECH

UNLESS OTHERWISE SPECIFIED:
DIMENSIONS ARE IN INCHES
TOLERANCES:
FRACTIONAL ±1/32
ONE DECIMAL PLACE ± 0.060
TWO DECIMAL PLACE ± 0.025
THREE DECIMAL PLACE ± 0.010
DO NOT SCALE DRAWING

PART NO.
3A-NUP-4C

DWG. NO. 3A-NUP-4C-ASSY

WEIGHT: 0.148 REV A

SCALE: 2:1.75 SHEET 1 OF 1

8 7 6 5 4 3 2 1

8 7 6 5 4 3 2 1