

REVISIONS		
REV.	DESCRIPTION	DATE
A	UPDATE DRAWING TO 2025 STANDARDS	1/15/2026

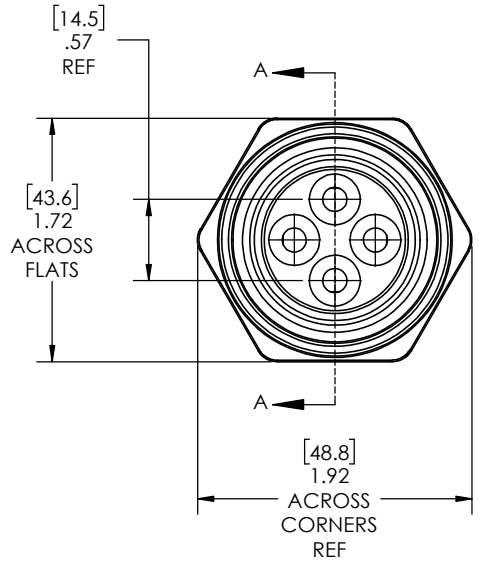

Expanded Min ID=0.60(15.2) REF
 [Recovered Max ID=0.19(4.8)] REF

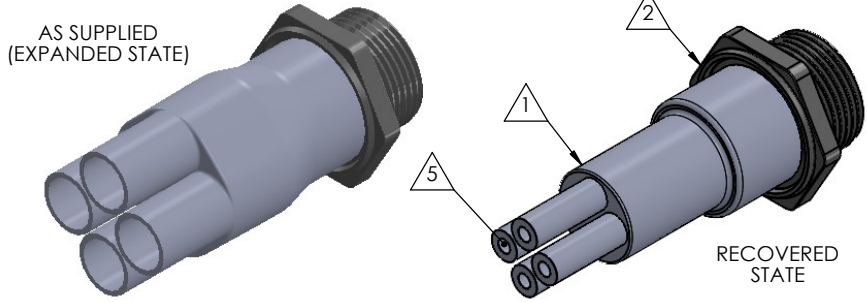
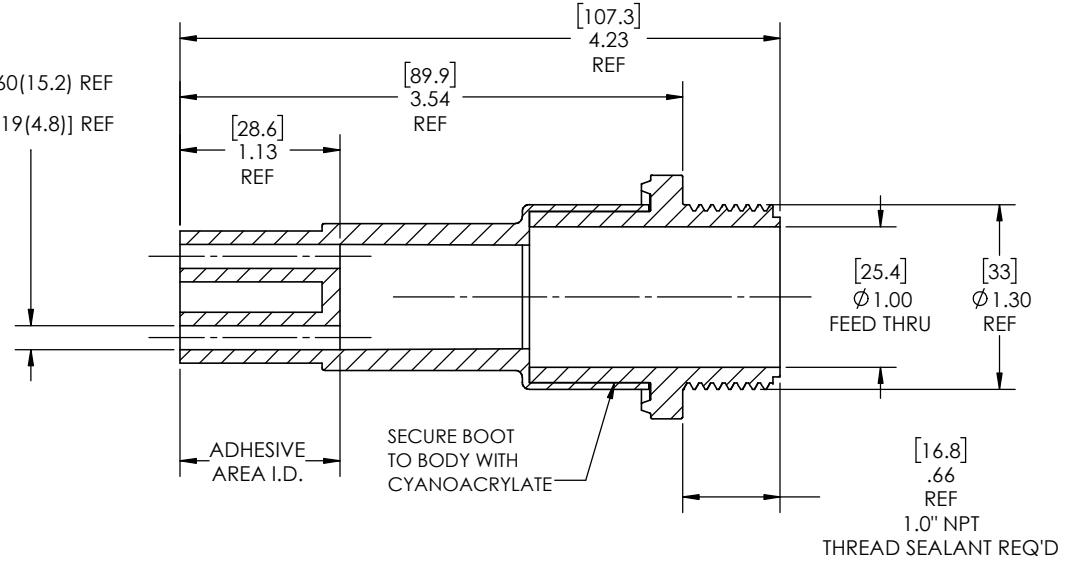

SECTION A-A
 RECOVERED
 SCALE 2 : 1.75

- NOTES:
- ITEM #1 HEAT SHRINKABLE BOOT MATERIAL IS IN ACCORDANCE WITH POLYOLEFIN STANDARDS DEFINED IN SAE AS81765/1 REFERENCE DIMENSIONS MAY DEVIATE AS MUCH AS +OR- 1/4"
 - FACTORY APPLIED HOT MELT ADHESIVE IS STANDARD

ITEM	PART DESCRIPTION	PART NO.	MATERIAL
1	Heat-shrinkable boot	NUBB4-2	Flame Retardant Polyolefin
2	Body	S-3AB	Glass Fiber Reinforced, PBT
5	Adhesive		Hotmelt Polyamide

NU-TECH

UNLESS OTHERWISE SPECIFIED: DIMENSIONS ARE IN INCHES TOLERANCES: FRACTIONAL ±1/32 ONE DECIMAL PLACE ± 0.060 TWO DECIMAL PLACE ± 0.025 THREE DECIMAL PLACE ± 0.010 DO NOT SCALE DRAWING	PART NO. 3A-NUP-4B	
	DWG. NO. 3A-NUP-4B-ASSY	
	WEIGHT: 0.098	REV A
	DRAWN: MLJ	DATE: 2/2/2026

PROPRIETARY AND CONFIDENTIAL
 THE INFORMATION CONTAINED IN THIS DRAWING IS THE SOLE PROPERTY OF Cross Technology INC. ANY REPRODUCTION IN PART OR AS A WHOLE WITHOUT THE WRITTEN PERMISSION OF Cross Technology INC. IS PROHIBITED.