

8 7 6 5 4 3 2 1

REVISIONS		
REV.	DESCRIPTION	DATE
A	UPDATE DRAWING TO 2025 STANDARDS	1/19/2026

AS SUPPLIED  
(EXPANDED STATE)

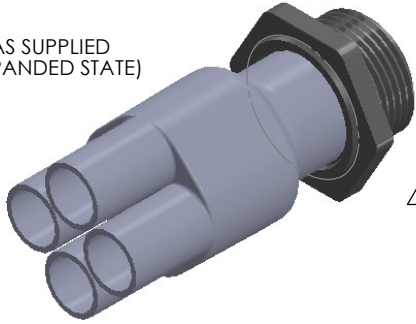

RECOVERED  
STATE

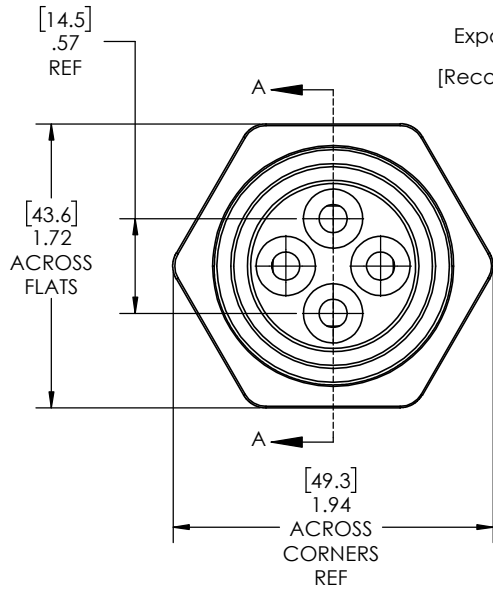
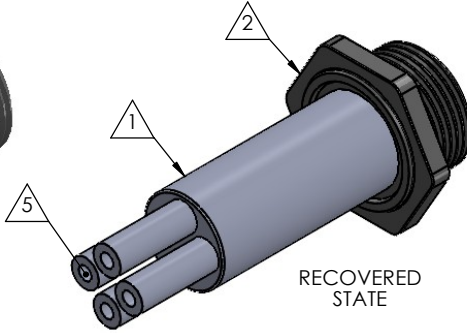

Expanded Min ID=0.60(15.2) REF  
[Recovered Max ID=0.18(4.6)] REF

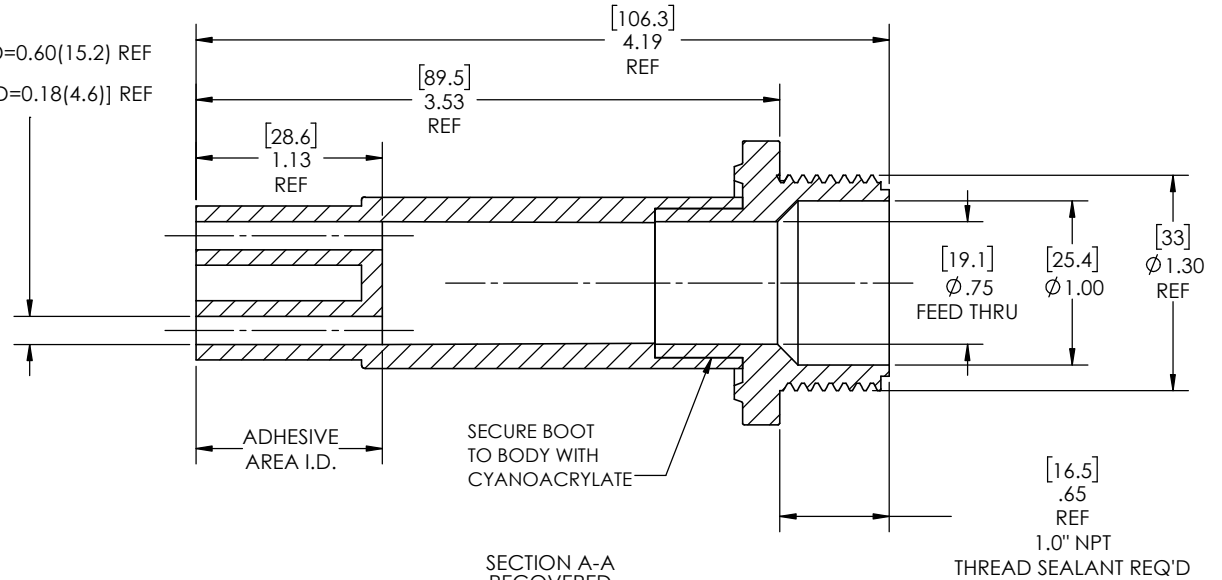

SECTION A-A  
RECOVERED  
SCALE 2 : 1.5

[16.5]  
.65  
REF  
1.0" NPT  
THREAD SEALANT REQ'D

NOTES:

- ITEM #1 HEAT SHRINKABLE BOOT MATERIAL IS IN ACCORDANCE WITH POLYOLEFIN STANDARDS DEFINED IN SAE AS81765/1 REFERENCE DIMENSIONS MAY DEVIATE AS MUCH AS +OR- 1/4"
- FACTORY APPLIED HOT MELT ADHESIVE IS STANDARD

ITEM	PART DESCRIPTION	PART NO.	MATERIAL
1	Heat-shrinkable boot	NUBB4-2	Flame Retardant Polyolefin
2	Body	P-3B	Glass Fiber Reinforced, PBT
5	Adhesive		Hotmelt Polyamide

**NU-TECH**

UNLESS OTHERWISE SPECIFIED:  
DIMENSIONS ARE IN INCHES  
TOLERANCES:  
FRACTIONAL ±1/32  
ONE DECIMAL PLACE ± 0.060  
TWO DECIMAL PLACE ± 0.025  
THREE DECIMAL PLACE ± 0.010  
DO NOT SCALE DRAWING

PART NO.  
**3-NUP-4B**

DWG. NO. 3-NUP-4B-ASSY

WEIGHT: 0.088 REV A

DRAWN: MLJ DATE: 2/2/2026 SCALE: 2:1.5 SHEET 1 OF 1

8 7 6 5 4 3 2 1