

8 7 6 5 4 3 2 1

AS SUPPLIED
(EXPANDED STATE)

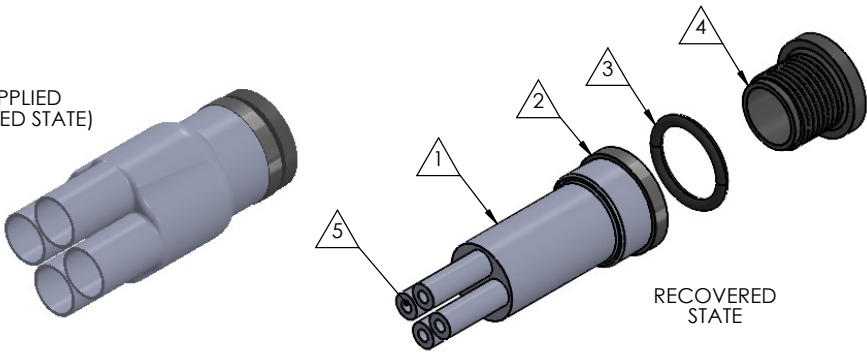

REVISIONS		
REV.	DESCRIPTION	DATE
A	UPDATE DRAWING TO 2025 STANDARDS	12/3/2025
B	REFINE DIMENSIONS AND DECIMAL PRECISION	12/16/2025
C	UPDATE TOLERANCE TABLE	12/30/2025

NOTE: REFERENCE FOR SEAL ASSEMBLY INSTALLATION:
ASSEMBLY MAY BE INSTALLED IN PANELS FROM
0.08" (2.0mm) - 0.35" (8.9mm).
RECOMMENDED DRILL HOLE DIAMETER
OF 1.00" (25.4mm)

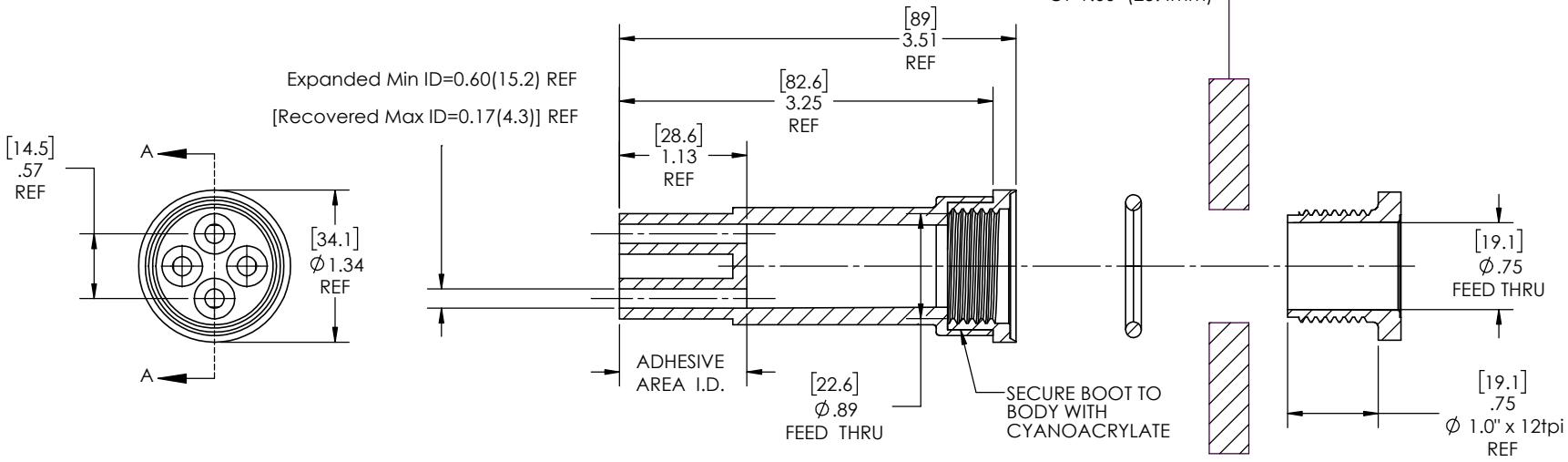

SECTION A-A
RECOVERED
SCALE 1:1

- NOTES:
- ITEM #1 HEAT SHRINKABLE BOOT MATERIAL IS IN ACCORDANCE WITH POLYOLEFIN STANDARDS DEFINED IN SAE AS81765/1 REFERENCE DIMENSIONS MAY DEVIATE AS MUCH AS +OR- 1/4"
 - FACTORY APPLIED HOT MELT ADHESIVE IS STANDARD

ITEM	PART DESCRIPTION	PART NO.	MATERIAL
1	Heat-shrinkable boot	NUBB4-2	Flame Retardant Polyolefin
2	Body	S-2XB	Glass Fiber Reinforced, PBT
3	O-ring	AS-214	Buna
4	Nut	S-2XN	Glass Fiber Reinforced, PBT
5	Adhesive		Hotmelt Polyamide

NU-TECH

UNLESS OTHERWISE SPECIFIED: DIMENSIONS ARE IN INCHES TOLERANCES: FRACTIONAL ± 1/32 ONE DECIMAL PLACE ± 0.060 TWO DECIMAL PLACE ± 0.025 THREE DECIMAL PLACE ± 0.010 DO NOT SCALE DRAWING	PART NO.	
	2X-NUS-4B	
	DWG. NO. 2X-NUS-4B-ASSY	
	WEIGHT: 0.084	REV C
DRAWN: MLJ	DATE: 2/3/2026	SCALE: 1:1
		SHEET 1 OF 1

8 7 6 5 4 3 2 1

8 7 6 5 4 3 2 1