

NOTE: REFERENCE FOR SEAL ASSEMBLY INSTALLATION:  
 ASSEMBLY MAY BE INSTALLED IN PANELS FROM  
 0.08"(2.0mm) - 0.35"(8.9mm).  
 RECCOMENDED DRILL HOLE DIAMETER  
 OF 1.00" (25.4mm)

REVISIONS		
REV.	DESCRIPTION	DATE
A	UPDATE DRAWING TO 2025 STANDARDS	3/12/2026

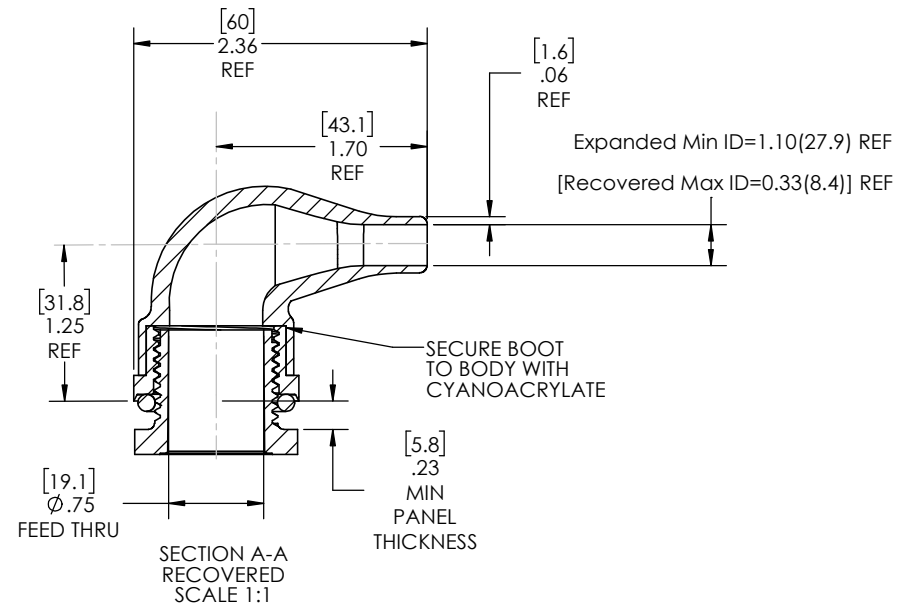
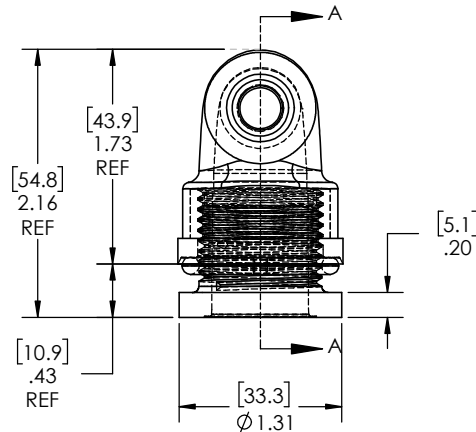
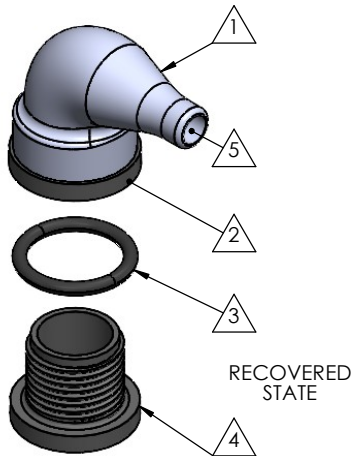
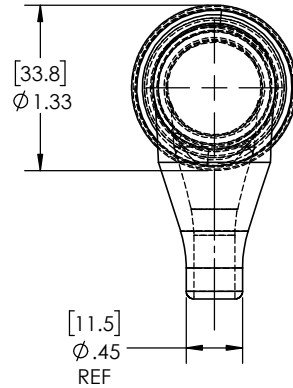
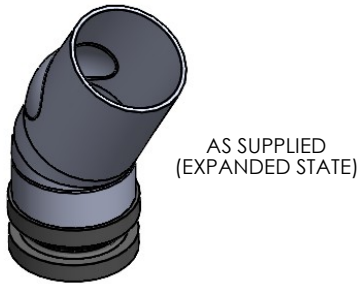

NOTES:

- ITEM#1 HEAT SHRINKABLE BOOT MATERIAL IS IN ACCORDANCE WITH POLYOLEFIN STANDARDS DEFINED IN SAE AS81765/1 REFERENCE DIMENSIONS MAY DEVIATE AS MUCH AS +OR- 1/4"
- FACTORY APPLIED HOT MELT ADHESIVE IS STANDARD

**PROPRIETARY AND CONFIDENTIAL**

THE INFORMATION CONTAINED IN THIS DRAWING IS THE SOLE PROPERTY OF Cross Technology INC. ANY REPRODUCTION IN PART OR AS A WHOLE WITHOUT THE WRITTEN PERMISSION OF Cross Technology INC. IS PROHIBITED.

ITEM	PART DESCRIPTION	PART NO.	MATERIAL
1	Heat-shrinkable boot	NU2R	Flame Retardant Polyolefin
2	Body	S-2B TRIMMED	Glass Fiber Reinforced, PBT
3	O-ring	AS-214	Buna
4	Nut	S-2XN	Glass Fiber Reinforced, PBT
5	Adhesive		Hotmelt Polyamide

**NU-TECH**

UNLESS OTHERWISE SPECIFIED:  
 DIMENSIONS ARE IN INCHES  
 TOLERANCES:  
 FRACTIONAL  $\pm 1/32$   
 ONE DECIMAL PLACE  $\pm 0.060$   
 TWO DECIMAL PLACE  $\pm 0.025$   
 THREE DECIMAL PLACE  $\pm 0.010$   
 DO NOT SCALE DRAWING

PART NO.  
**2X-NUS-2R**

DWG. NO. **2X-NUS-2R**

WEIGHT: **0.052** REV **A**

DRAWN: MLJ DATE: 5/13/2026 SCALE: 1:1 SHEET 1 OF 1