

8 7 6 5 4 3 2 1

REVISIONS		
REV.	DESCRIPTION	DATE
A	UPDATE DRAWING TO 2025 STANDARDS	12/1/2025
B	REFINE DIMENSIONS AND DECIMAL PRECISION	12/16/2025
C	UPDATE TOLERANCE TABLE	12/30/2025

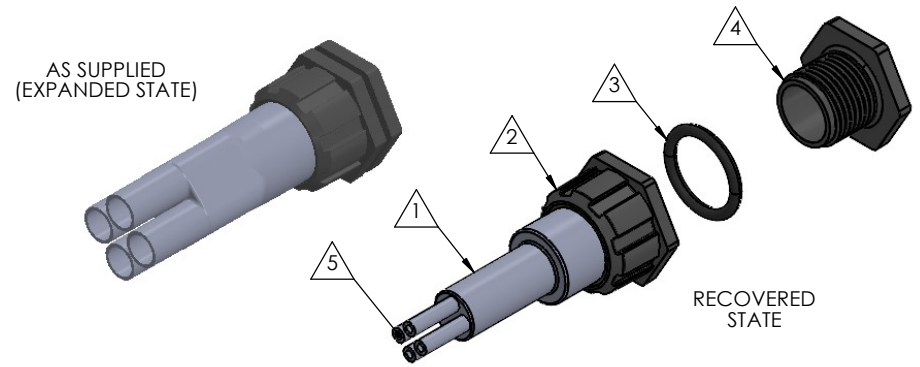

NOTE: REFERENCE FOR SEAL ASSEMBLY INSTALLATION:
 ASSEMBLY MAY BE INSTALLED IN PANELS FROM
 0.07" (1.8mm) - 0.38" (9.5mm).
 RECOMMENDED DRILL HOLE DIAMETER
 OF 1.00" (25.4mm)

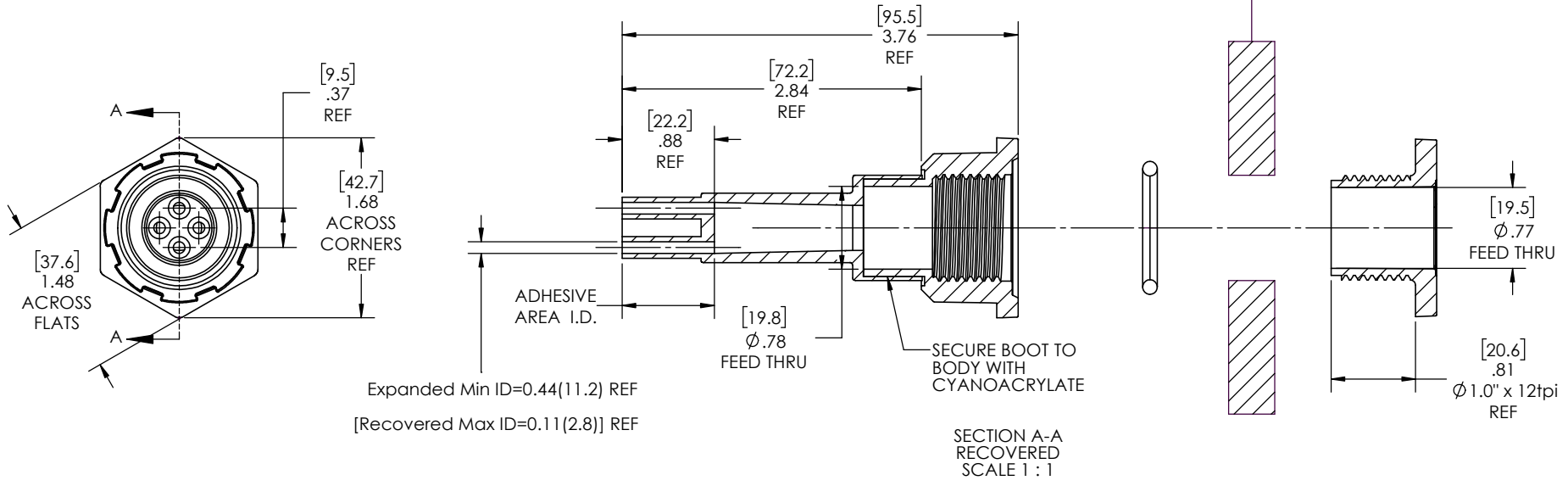

- NOTES:
- ITEM #1 HEAT SHRINKABLE BOOT MATERIAL IS IN ACCORDANCE WITH POLYOLEFIN STANDARDS DEFINED IN SAE AS81765/1 REFERENCE DIMENSIONS MAY DEVIATE AS MUCH AS +OR- 1/4"
 - FACTORY APPLIED HOT MELT ADHESIVE IS STANDARD

ITEM	PART DESCRIPTION	PART NO.	MATERIAL
1	Heat-shrinkable boot	NUBB4-1	Flame Retardant Polyolefin
2	Body	S-2B	Glass Fiber Reinforced, PBT
3	O-ring	AS-214	Buna
4	Nut	S-1/S-2N	Glass Fiber Reinforced, PBT
5	Adhesive		Hotmelt Polyamide

NU-TECH

UNLESS OTHERWISE SPECIFIED: DIMENSIONS ARE IN INCHES TOLERANCES: FRACTIONAL: 1/32 ONE DECIMAL PLACE ± 0.060 TWO DECIMAL PLACE ± 0.025 THREE DECIMAL PLACE ± 0.010 DO NOT SCALE DRAWING	PART NO. 2-NUS-4A	
	DWG. NO. 2-NUS-4A-ASSY	
	WEIGHT: 0.084	REV C
	SCALE: 1:1	SHEET 1 OF 1

PROPRIETARY AND CONFIDENTIAL
 THE INFORMATION CONTAINED IN THIS DRAWING IS THE SOLE PROPERTY OF
 Cross Technology INC. ANY REPRODUCTION IN PART OR AS A WHOLE
 WITHOUT THE WRITTEN PERMISSION OF Cross Technology INC. IS PROHIBITED.

8 7 6 5 4 3 2 1