

NOTE: REFERENCE FOR SEAL ASSEMBLY INSTALLATION:
 ASSEMBLY MAY BE INSTALLED IN PANELS FROM
 0.08"(2.0mm) - 0.39"(9.9mm).
 RECCOMENDED DRILL HOLE DIAMETER
 OF 1.00" (25.4mm)

REVISIONS		
REV.	DESCRIPTION	DATE
A	UPDATE DRAWING TO 2025 STANDARDS	5/8/2026

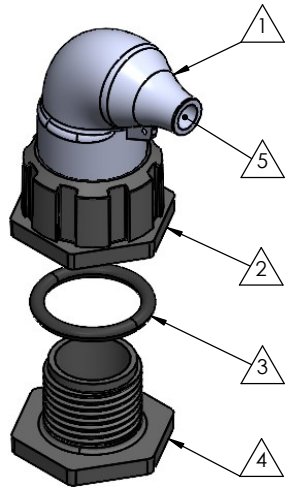

RECOVERED
STATE

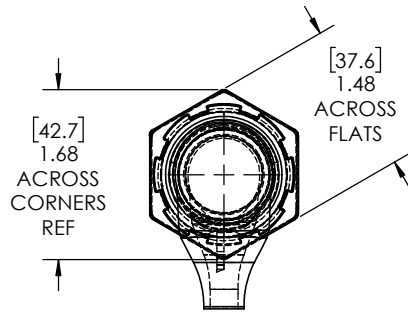
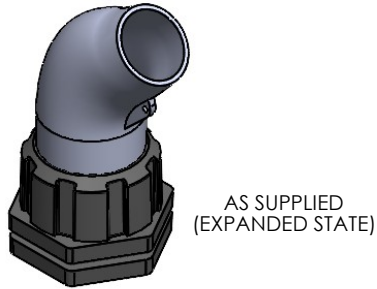
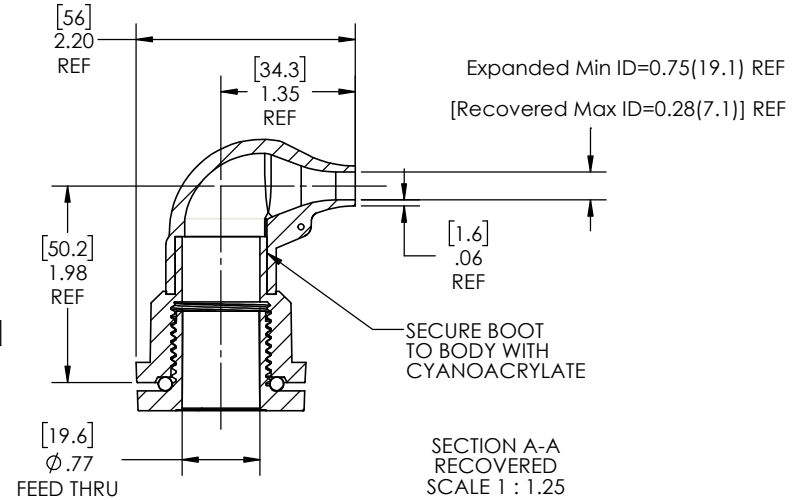
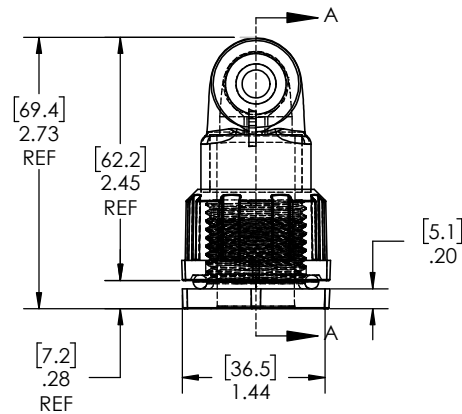

NOTES:

- ITEM#1 HEAT SHRINKABLE BOOT MATERIAL IS IN ACCORDANCE WITH POLYOLEFIN STANDARDS DEFINED IN SAE AS81765/1 REFERENCE DIMENSIONS MAY DEVIATE AS MUCH AS +OR- 1/4"
- FACTORY APPLIED HOT MELT ADHESIVE IS STANDARD

PROPRIETARY AND CONFIDENTIAL

THE INFORMATION CONTAINED IN THIS DRAWING IS THE SOLE PROPERTY OF Cross Technology INC. ANY REPRODUCTION IN PART OR AS A WHOLE WITHOUT THE WRITTEN PERMISSION OF Cross Technology INC. IS PROHIBITED.

ITEM	PART DESCRIPTION	PART NO.	MATERIAL
1	Heat-shrinkable boot	NU1R	Flame Retardant Polyolefin
2	Body	S-2B	Glass Fiber Reinforced, PBT
3	O-ring	AS-214	Buna
4	Nut	S1-S2N	Glass Fiber Reinforced, PBT
5	Adhesive		Hotmelt Polyamide

NU-TECH

UNLESS OTHERWISE SPECIFIED:
 DIMENSIONS ARE IN INCHES
 TOLERANCES:
 FRACTIONAL ±1/32
 ONE DECIMAL PLACE ± 0.060
 TWO DECIMAL PLACE ± 0.025
 THREE DECIMAL PLACE ± 0.010
 DO NOT SCALE DRAWING

PART NO.
2-NUS-1R

DWG. NO. **2-NUS-1R**

WEIGHT: **0.084** REV **A**

DRAWN: MLJ DATE: 5/13/2026 SCALE: 1:1.25 SHEET 1 OF 1