

8 7 6 5 4 3 2 1

REVISIONS		
REV.	DESCRIPTION	DATE
A	UPDATE DRAWING TO 2025 STANDARDS	1/14/2026

AS SUPPLIED
(EXPANDED STATE)

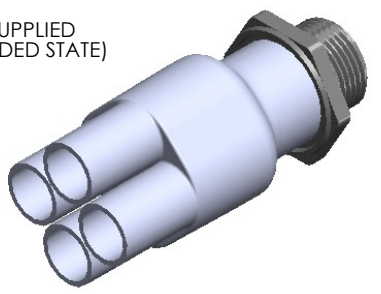

RECOVERED
STATE

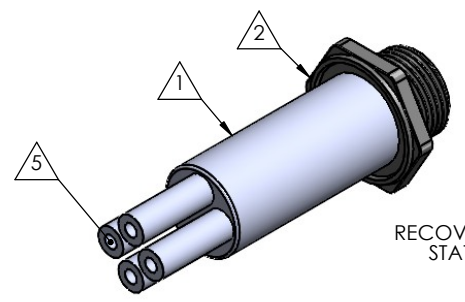

D

D

C

C

B

B

A

A

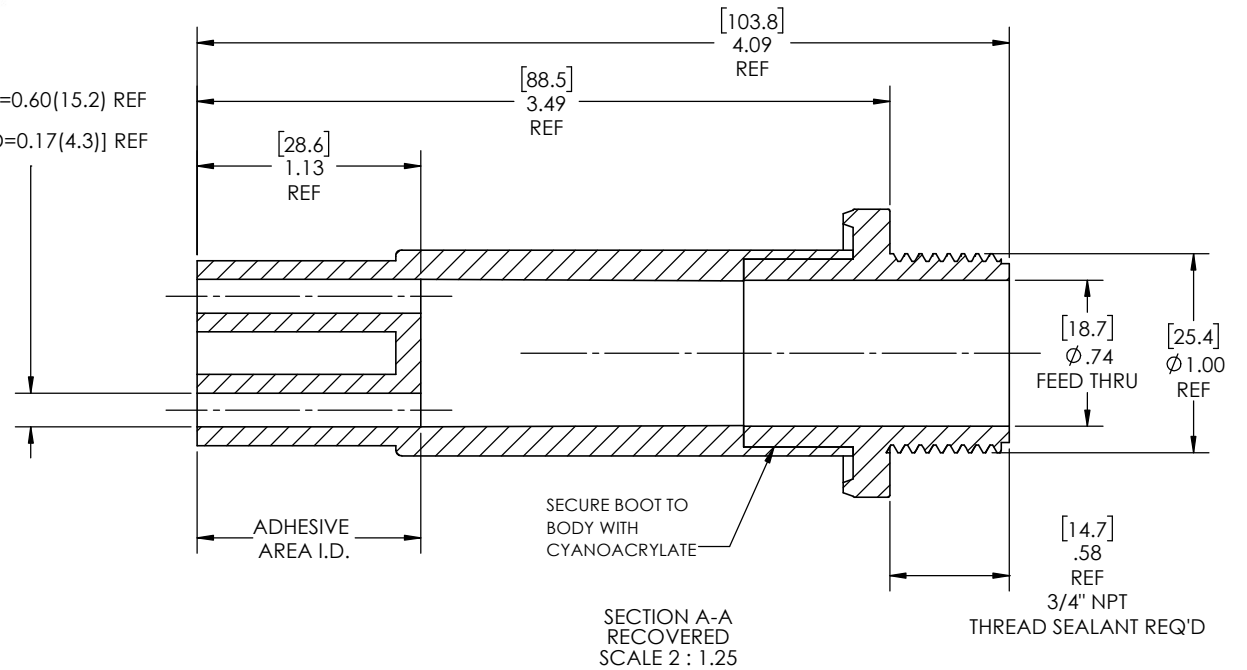
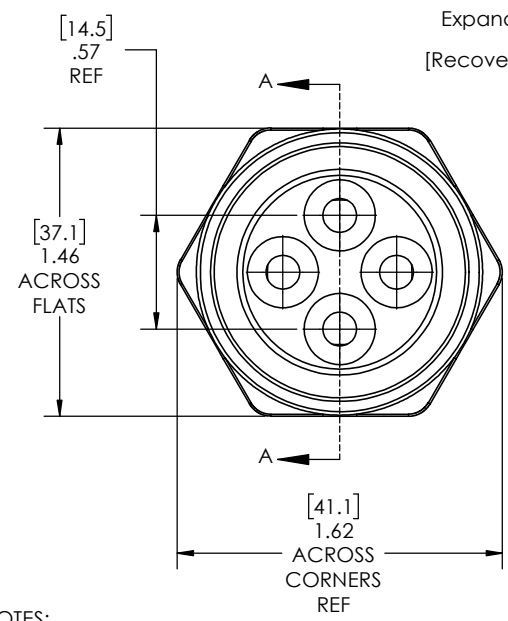

NOTES:

- ITEM #1 HEAT SHRINKABLE BOOT MATERIAL IS IN ACCORDANCE WITH POLYOLEFIN STANDARDS DEFINED IN SAE AS81765/1 REFERENCE DIMENSIONS MAY DEVIATE AS MUCH AS +OR- 1/4"
- FACTORY APPLIED HOT MELT ADHESIVE IS STANDARD

ITEM	PART DESCRIPTION	PART NO.	MATERIAL
1	Heat-shrinkable boot	NUBB4-2	Flame Retardant Polyolefin
2	Body	P-2B	Glass Fiber Reinforced, PBT
5	Adhesive		Hotmelt Polyamide

NU-TECH

UNLESS OTHERWISE SPECIFIED:
DIMENSIONS ARE IN INCHES
TOLERANCES:
FRACTIONAL ±1/32
ONE DECIMAL PLACE ± 0.060
TWO DECIMAL PLACE ± 0.025
THREE DECIMAL PLACE ± 0.010
DO NOT SCALE DRAWING

PART NO.	2-NUP-4B	
DWG. NO.	2-NUP-4B-ASSY	
WEIGHT:	0.067	REV A

PROPRIETARY AND CONFIDENTIAL
THE INFORMATION CONTAINED IN THIS DRAWING IS THE SOLE PROPERTY OF Cross Technology INC. ANY REPRODUCTION IN PART OR AS A WHOLE WITHOUT THE WRITTEN PERMISSION OF Cross Technology INC. IS PROHIBITED.

8 7 6 5 4 3 2 1