

8 7 6 5 4 3 2 1

REVISIONS		
REV.	DESCRIPTION	DATE
A	UPDATE DRAWING TO 2025 STANDARDS	3/27/2026

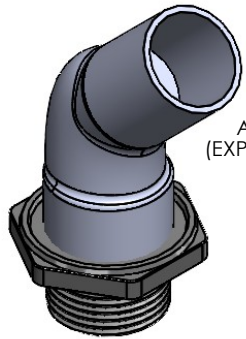

AS SUPPLIED
(EXPANDED STATE)

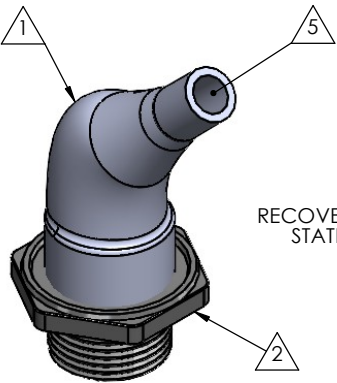
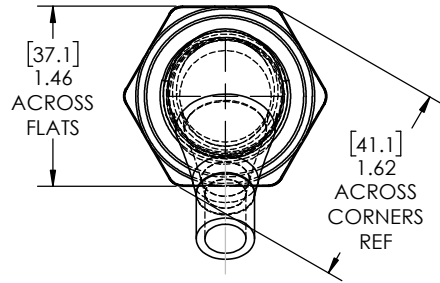

RECOVERED
STATE

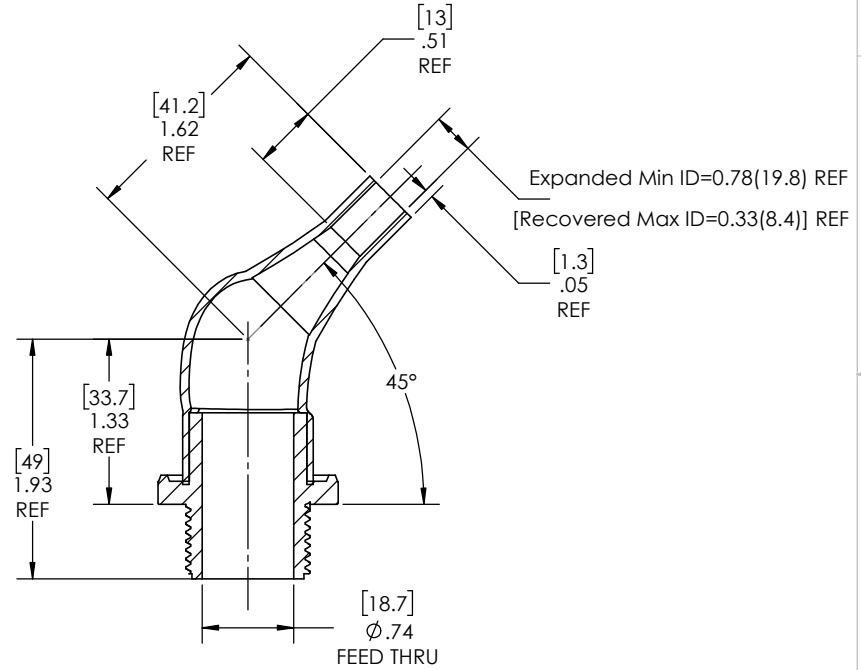
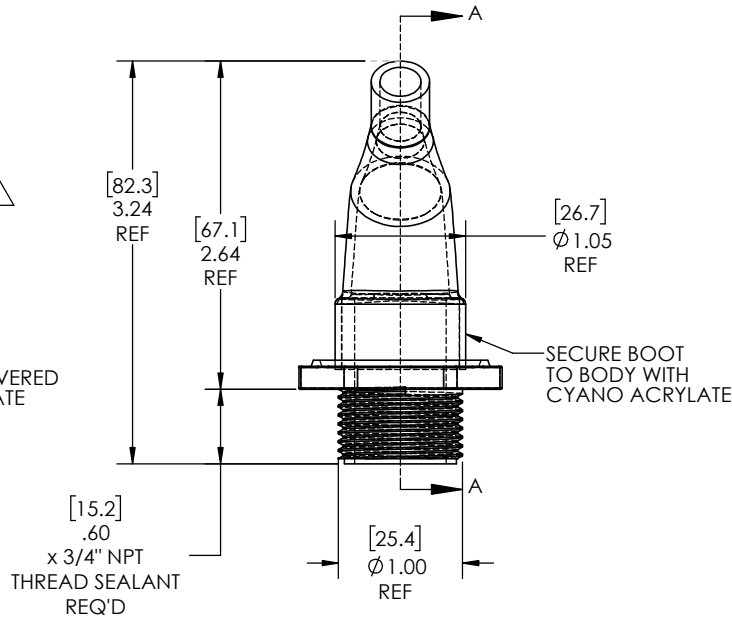

NOTES:

- ITEM#1 HEAT SHRINKABLE BOOT MATERIAL IS IN ACCORDANCE WITH POLYOLEFIN STANDARDS DEFINED IN SAE AS81765/1 REFERENCE DIMENSIONS MAY DEVIATE AS MUCH AS +OR- 1/4"
- FACTORY APPLIED HOT MELT ADHESIVE IS STANDARD

PROPRIETARY AND CONFIDENTIAL

THE INFORMATION CONTAINED IN THIS DRAWING IS THE SOLE PROPERTY OF Cross Technology INC. ANY REPRODUCTION IN PART OR AS A WHOLE WITHOUT THE WRITTEN PERMISSION OF Cross Technology INC. IS PROHIBITED.

ITEM	PART DESCRIPTION	PART NO.	MATERIAL
1	Heat-shrinkable boot	NU2-45	Flame Retardant Polyolefin
2	Body	P-2B	Glass Fiber Reinforced, PBT
5	Adhesive		Hotmelt Polyamide

NU-TECH

UNLESS OTHERWISE SPECIFIED:
DIMENSIONS ARE IN INCHES
TOLERANCES:
FRACTIONAL ±1/32
ONE DECIMAL PLACE ± 0.060
TWO DECIMAL PLACE ± 0.025
THREE DECIMAL PLACE ± 0.010

DO NOT SCALE DRAWING

DRAWN: MLJ DATE: 5/5/2026

PART NO.
2-NUP-2-45

DWG. NO. 2-NUP-2-45

WEIGHT: 0.04 REV A

SCALE: 1:1 SHEET 1 OF 1

8 7 6 5 4 3 2 1