

NOTE: REFERENCE FOR SEAL ASSEMBLY INSTALLATION:
 ASSEMBLY MAY BE INSTALLED IN PANELS FROM
 0.07" (1.8mm) - 0.38" (9.5mm).
 RECCOMENDED DRILL HOLE DIAMETER
 OF 1.00" (25.4mm)

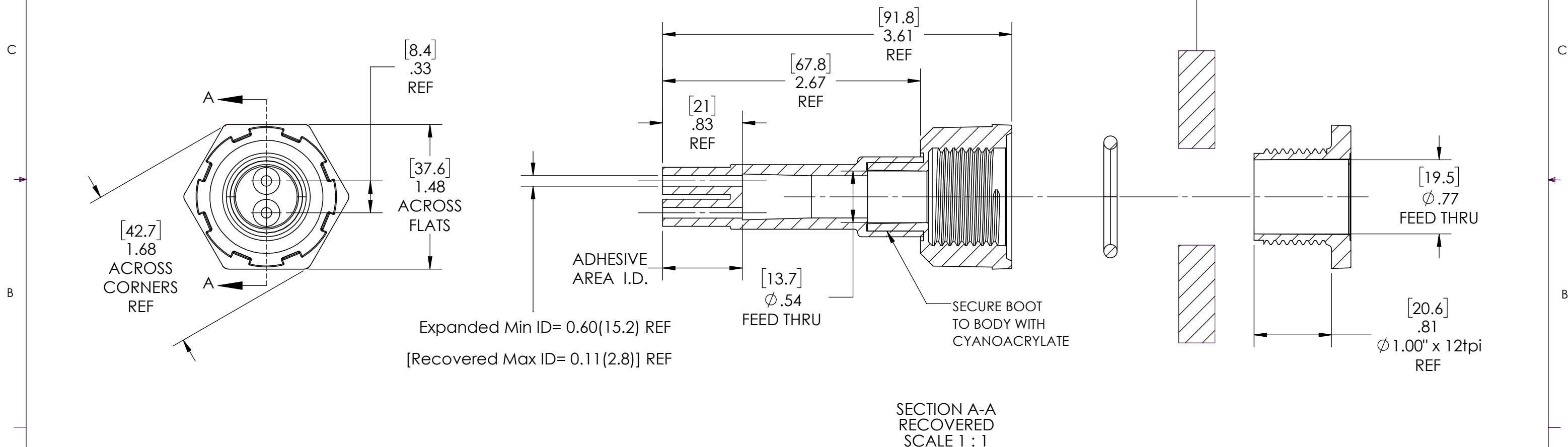

- NOTES:
- ITEM#1 HEAT SHRINKABLE BOOT MATERIAL IS IN ACCORDANCE WITH POLYOLEFIN STANDARDS DEFINED IN SAE AS81765/1 REFERENCE DIMENSIONS MAY DEVIATE AS MUCH AS +OR- 1/4"
 - FACTORY APPLIED HOT MELT ADHESIVE IS STANDARD

ITEM	PART DESCRIPTION	PART NO.	MATERIAL
①	Heat-shrinkable boot	NUBB2-1OE	Flame Retardant Polyolefin
②	Body	S-1B	Glass Fiber Reinforced, PBT
③	O-ring	AS-214	Buna
④	Nut	S-1/S-2N	Glass Fiber Reinforced, PBT
⑤	Adhesive		Hotmelt Polyamide

NU-TECH

UNLESS OTHERWISE SPECIFIED: DIMENSIONS ARE IN INCHES TOLERANCES: FRACTIONAL ± 1/32 ONE DECIMAL PLACE ± 0.060 TWO DECIMAL PLACE ± 0.025 THREE DECIMAL PLACE ± 0.010 DO NOT SCALE DRAWING	PART NO.		1-NUS-2AOE	
	DWG. NO.			1-NUS-2AOE-ASSY
	WEIGHT:	0.081	REV	C
	DRAWN: MLJ	DATE: 2/3/2026	SCALE:	1:1

PROPRIETARY AND CONFIDENTIAL
 THE INFORMATION CONTAINED IN THIS DRAWING IS THE SOLE PROPERTY OF Cross Technology INC. ANY REPRODUCTION IN PART OR AS A WHOLE WITHOUT THE WRITTEN PERMISSION OF Cross Technology INC. IS PROHIBITED.