

8 7 6 5 4 3 2 1

REVISIONS		
REV.	DESCRIPTION	DATE
A	UPDATE DRAWING TO 2025 STANDARDS	11/19/2025

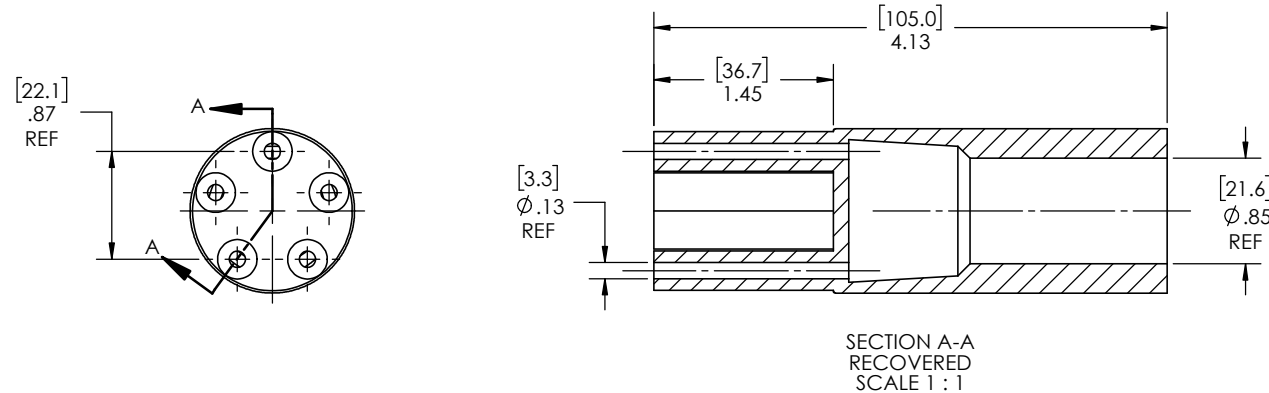
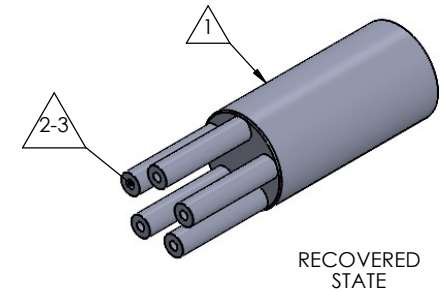
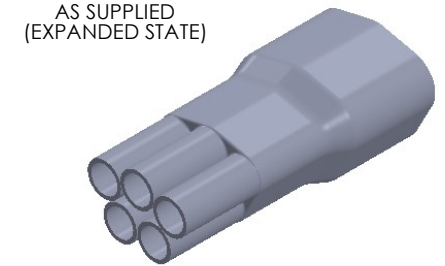
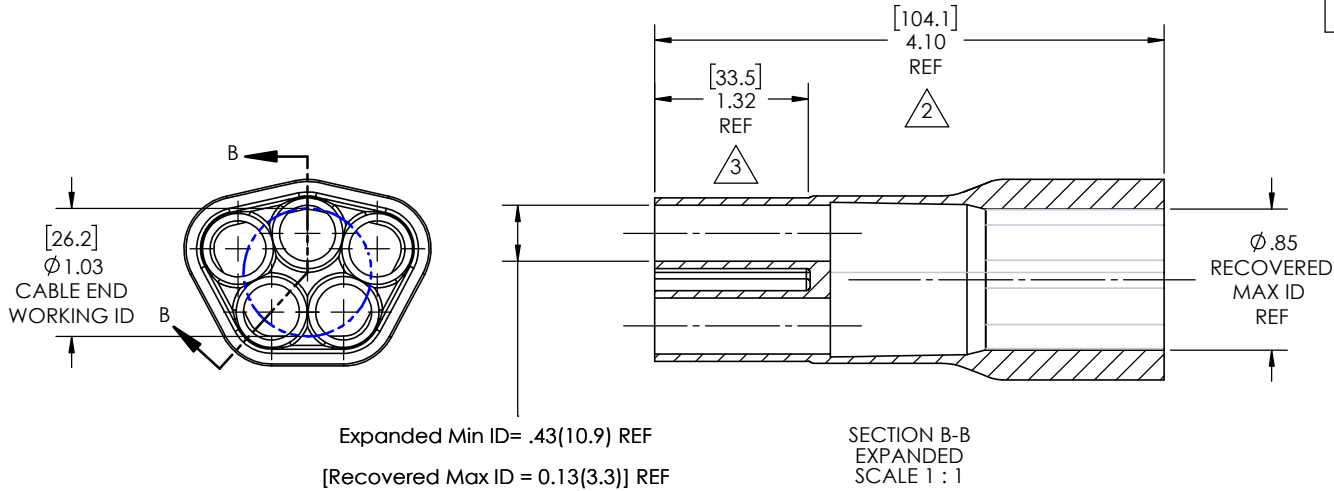

NOTES:

- ITEM#1 - HEAT SHRINKABLE BOOT MATERIAL IS IN ACCORDANCE WITH POLYOLEFIN STANDARDS DEFINED IN SAE AS81765/1 REFERENCE DIMENSIONS MAY DEVIATE AS MUCH AS +OR- 1/4"
- ITEM#2 - FACTORY APPLIED HOT MELT ADHESIVE IS STANDARD - INTERIOR SURFACES.
- ITEM #3 - BOOTS INTENDED FOR NU-TECH ASSEMBLIES WILL HAVE HOTMELT APPLIED INSIDE LEGS ONLY AFTER ASSEMBLY HAS BEEN COMPLETED.

ITEM	PART DESCRIPTION	PART NO.	MATERIAL
1	HEAT SHRINKABLE BOOT	M-NUBB5-1	FLAME RETARDANT POLYOLEFIN
2	ADHESIVE		HOTMELT POLYAMIDE

**PROPRIETARY AND CONFIDENTIAL**  
 THE INFORMATION CONTAINED IN THIS DRAWING IS THE SOLE PROPERTY OF Cross Technology INC. ANY REPRODUCTION IN PART OR AS A WHOLE WITHOUT THE WRITTEN PERMISSION OF Cross Technology INC. IS PROHIBITED.

**NU-TECH**

UNLESS OTHERWISE SPECIFIED: DIMENSIONS ARE IN INCHES TOLERANCES: FRACTIONAL ±1/16 ONE DECIMAL PLACE ± 0.200 TWO DECIMAL PLACE ± 0.100 THREE DECIMAL PLACE ± 0.050	PART DESC. <b>NUBB5-1</b>
DWG. NO. NUBB5-1	REV A
WEIGHT: 0.079	SCALE: 1:1
DRAWN: MLJ DATE: 4/20/2026	SHEET 1 OF 1

8 7 6 5 4 3 2 1