

REVISIONS		
REV.	DESCRIPTION	DATE
A	UPDATE DRAWING TO 2025 STANDARDS	11/11/2025

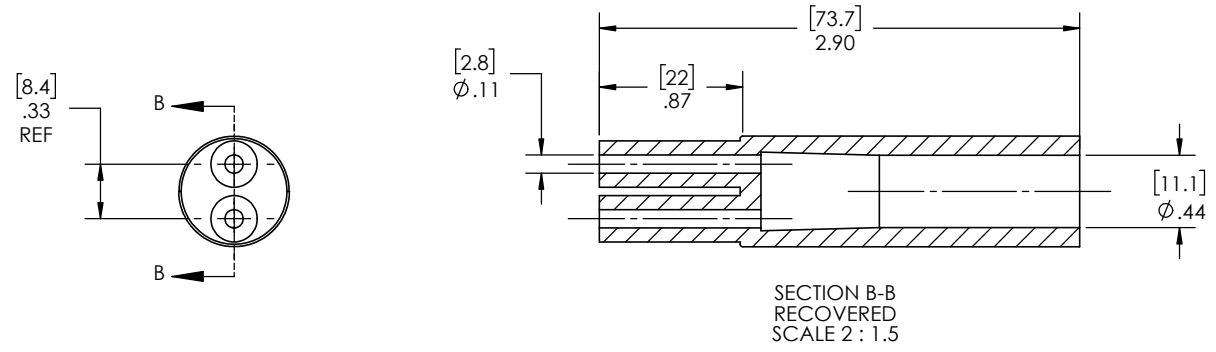
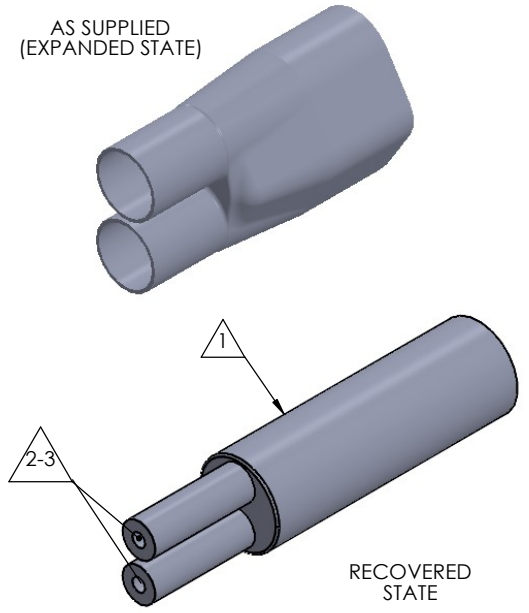
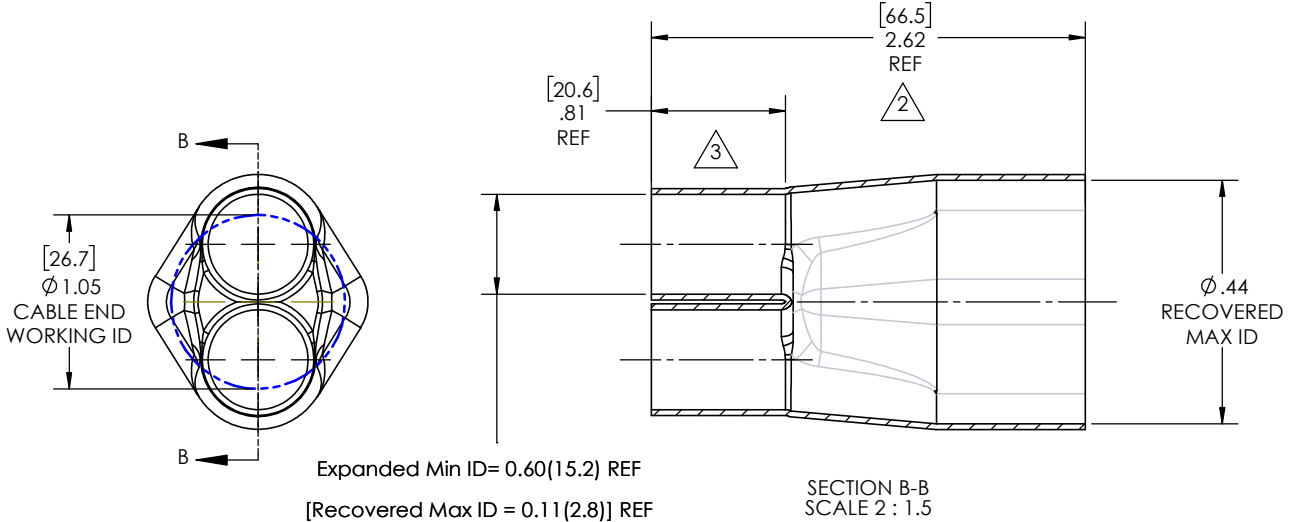

- NOTES:
- ITEM#1 - HEAT SHRINKABLE BOOT MATERIAL IS IN ACCORDANCE WITH POLYOLEFIN STANDARDS DEFINED IN SAE AS81765/1 REFERENCE DIMENSIONS MAY DEVIATE AS MUCH AS +OR- 1/4"
 - ITEM#2 - FACTORY APPLIED HOT MELT ADHESIVE IS STANDARD - INTERIOR SURFACES.
 - ITEM #3 - BOOTS INTENDED FOR NU-TECH ASSEMBLIES WILL HAVE HOTMELT APPLIED INSIDE LEGS ONLY AFTER ASSEMBLY HAS BEEN COMPLETED.

ITEM	PART DESCRIPTION	PART NO.	MATERIAL
1	HEAT SHRINKABLE BOOT	M-NUBB2-1	FLAME RETARDANT POLYOLEFIN
2	ADHESIVE		HOTMELT POLYAMIDE

PROPRIETARY AND CONFIDENTIAL

THE INFORMATION CONTAINED IN THIS DRAWING IS THE SOLE PROPERTY OF Cross Technology INC. ANY REPRODUCTION IN PART OR AS A WHOLE WITHOUT THE WRITTEN PERMISSION OF Cross Technology INC. IS PROHIBITED.

NU-TECH

UNLESS OTHERWISE SPECIFIED: DIMENSIONS ARE IN INCHES TOLERANCES: FRACTIONAL ±1/16 ONE DECIMAL PLACE ± 0.200 TWO DECIMAL PLACE ± 0.100 THREE DECIMAL PLACE ± 0.050	PART DESC. NUBB2-1OE
DWG. NO. NUBB2-1OE	REV A
WEIGHT: 0.013	SCALE: 2:1.5
DRAWN: MLJ	DATE: 4/11/2026
SHEET 1 OF 1	